



Foshan Yi Wei Xin Technology Co., Ltd

Project Review for Tooling Development

- Project Summary
- 1. Multicolor Series Tools
- 2. 1K Lampshade Tools
- 3. Thick-Walled Lens Tools
- 4. Electroplating and High-gloss Tools



OEM	PJT	Part Name	Kick-off	Remark
KOITO	E*8	HL LENS	2022.04	Opposite Injection
KOITO	H*3	HL LENS	2022.12	Opposite Injection
WINNER	P*3	Front Fog Lampshade	2021.06	Rotation Table(Reversed)
KOITO	P*3B	RCL Lampshade	2019.06	Vertical Rotation
KOITO	P*3B	TL Lampshade	2019.06	Vertical Rotation
WINNER	P*5	Front Fog Lampshade	2021.10	Rotation Table(Reversed)
KOITO	G*5	TL LENS	2019.06	Vertical Rotation
KOITO	F#0	TL LENS	2022.07	Vertical Rotation
KOITO	2*Y	TL LENS	2021.07	Rotation Table
HangTian	T*9C	Right Rear Quarter Panel Body	2021.10	Rotation Table
HangTian	T*9C	Left Rear Quarter Panel Body	2021.10	Rotation Table
HangTian	M*E	Triangle Plate	2021.06	Rotation Table
WNNER	B*1E	Turn signal with reverse Lampshade	2022.12	Rotation Table



OEM	PJT	Part Name	Kick-off	Remark
WINNER	C03	High-mount Brake Lampshade	2022.08	Rotation Table
VALEO	C*1E	Door Lamp Lens	2022.12	Rotation Table
VALEO	C*1E	Console Lens	2022.12	Rotation Table
WEIGAO	A19	High-mount Brake Lampshade	2023.09	Rotation Table
Shuangying	E12	Front Door Trim Panel	2022.12	Opposite Injection
Shuangying	E12	Front Door Trim Panel	2022.12	Opposite Injection
WINNER	P*2	High Brake Light Inner Lens	2022.04	
WINNER	B*6	Reverse Lampshade with Backup Light	2022.04	
WINNER	SA*9	Door light cover	2022.04	
WINNER	A07	Rear fog Lampshade	2021.12	
WNNER	B*1E	Turn Signal with Reverse lens	2022.05	
WNNER	B*6	Rear Fog Lamp Inner lens	2022.04	
VALEO	B*1E	LIGHT GUIGE	2022.05	



OEM	PJT	Part Name	Kick-off	Remark
WINNER	B*6	Front Fog Lamp Reflector	2022.04	
KOITO	D*2	HL EXT	2021.05	
KOITO	E*8	HL EXT	2021.10	
KOITO	3*1D	TL BG REF	2023.04	
KOITO	H*3	A LAMP EXT-A	2022.12	
KOITO	H*3	A LAMP EXT-B	2022.12	
VALEO	B*1E	Camer Cover	2022.05	
Tafu	A0505	Front Fog Lamp Reflector	2023.10	

X P E N G

P7
-HL LENS
-HL EXT



X P E N G



G9
-HL LENS
-A LAMP EXT-A
-HL EXT



X P E N G

G6
-TL LENS





QASHQAI
-RCL Lampshade
-TL Lampshade





HONDA



HONDA ZR-V
-TL LENS





ZEEKR-X
-Turn signal with reverse
Lampshade





ZEEKR

- ZEEKR 007
- Door Lamp Lens
- Console Lens
- Front Fog Lamp Reflector
- LIGHT GUIDE





AVATR
-Front Door Trim Panel





CAMRY
-TL HG REF
-TL BG REF

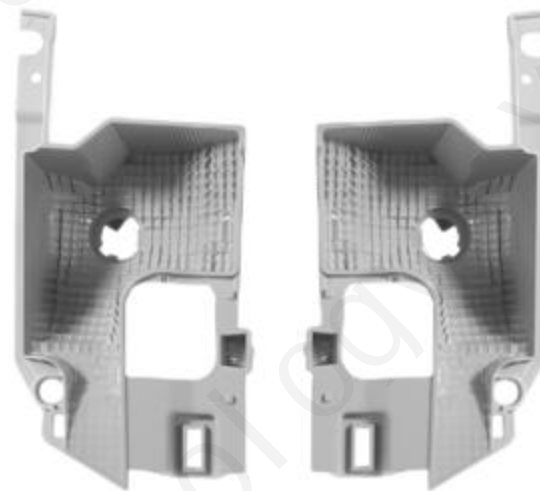

➤ 1. Multicolor Series Tools

Features

1, Divided by material

- 1. Same materials with different colors
- 2. Different materials with same colors
- 3. Different materials with different colors
- 4. Different materials with different hardness

2, Divided by Tooling Structure

- 1. Integral Mold
- 2. Separate Mold
- 3. Standard Mold (Injection Gate on Cavity Side)
- 4. Reverse Mold

3, Divided by IMM

- 1. Opposite Stack Rotation Injection
- 2. Horizontal Rotation Injection
- 3. Vertical Rotation Injection

Multi-color mold involved in all kinds of molds, our company has the corresponding development cases,

Can correspond :

Different material,
Different structure,
Different machine,

All kinds of multi-color mold development and production. The following is the introduction of relevant development cases:

1st: clear part



2ed: Black part

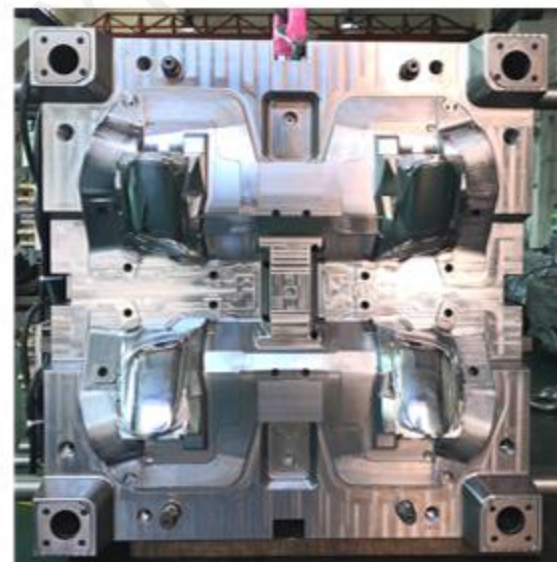
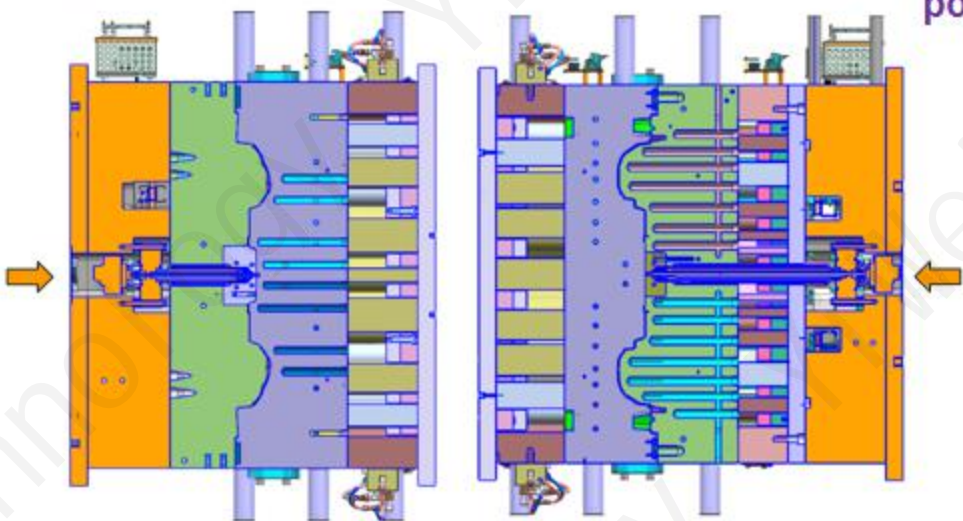

【Type: Opposite Injection, Central Rotation, Separate, Same Material with Different Color, Reversed Mold】

【Difficulties: Mirror sealing, which cannot have problems such as pressure marks, iron powder, bright lines, cracking, deformation, etc.】

Product Information:

Customer: KOITO
 Project Name: E*8
 Product Name: HL LENS
 Product Size: 322*291*242
 Product Material: PC
 black+PC clear
 Product Weight: 513.3g

Tools Information:

Type: 1800T Opposite two-component machine
 Hot runner: masters 8 points
 needle valve
 Tool Size: 1200*1200*1040*2
 Tools Weight: 7230KG
 Cavity: 1+1
 Cycle time: 48S
 Make time: 2022.04



1st:PC clear

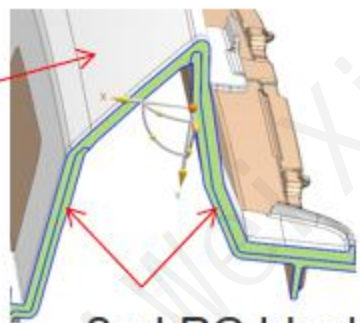

2ed:PC black



【Type: Opposite Injection, Central Rotation, Separate, Same Material with Different Color, Reversed mold】

【Difficulties: Appearance parts, mirror sealing, avoiding problems such as pressure marks, iron powder, bright lines, cracking, deformation, etc.】

Product Information :

Customer : GKOITO
 Project Name : H*3
 Product Name : HL LENS
 Product Size : 983*98*138
 Product Material : PC
 black+PC clear
 Product Weight : 933.7g

Tools Information :

Type: 1800T Opposite two-component machine
 Hot runner: masters 8 points
 needle valve
 Tool Size : 1200*1200*1110*2
 Tool Weight: 8980KG*2
 Cavity: 1+1
 Cycle time : 48S
 Make Time: 2022.12

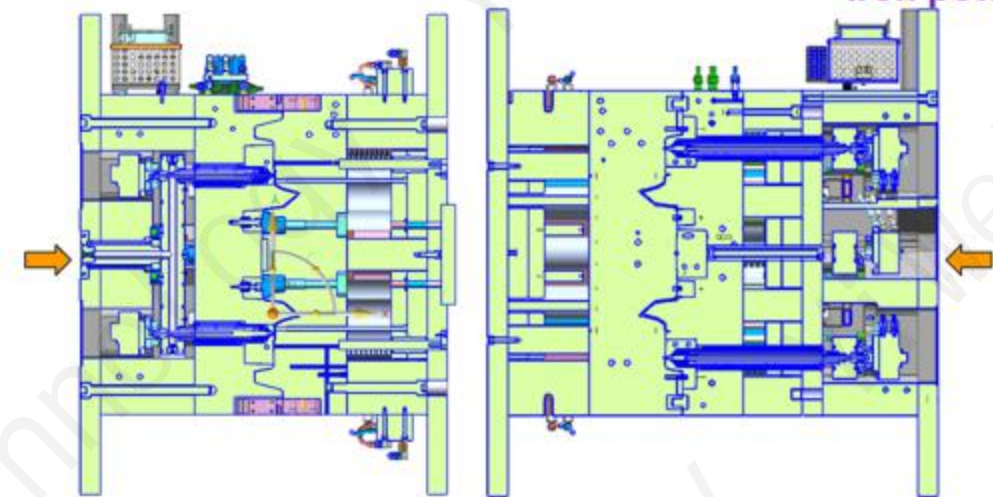

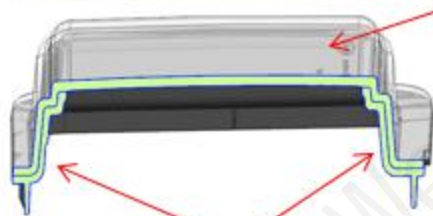

1st: clear

2ED: black part

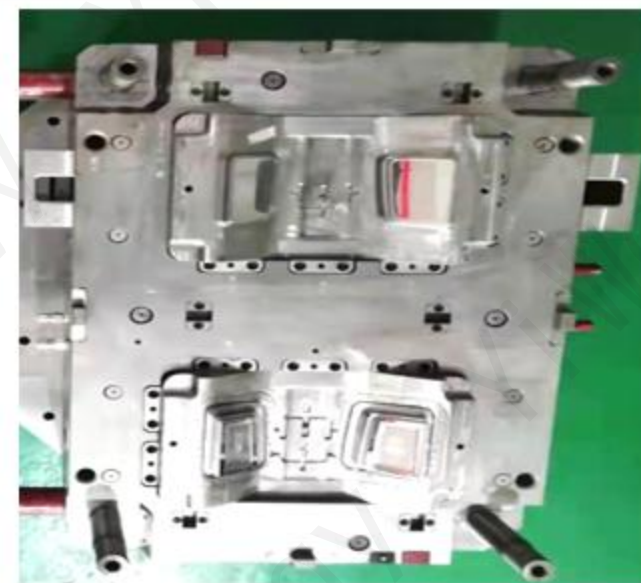
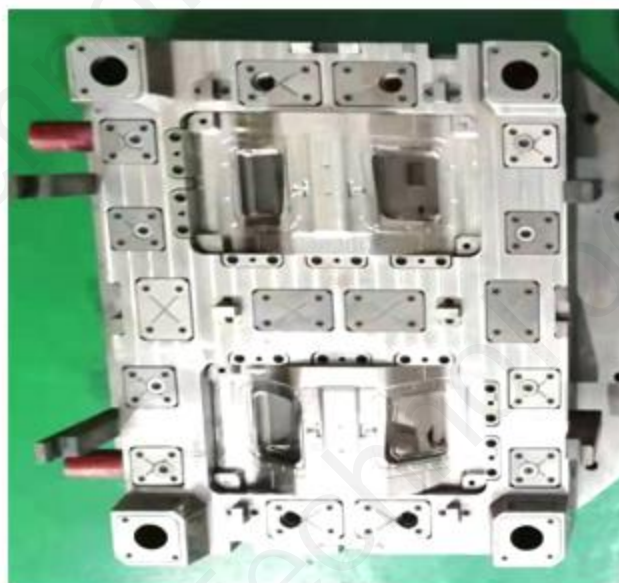
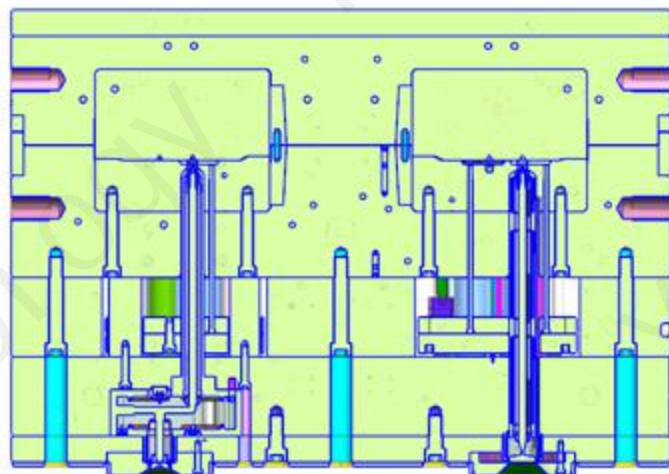

【Type: Horizontal Rotation, Integral, Same Material with Different Color, Reverse】

【Difficulties: Mirror sealing, which cannot have problems such as pressure marks, iron powder, bright lines, cracking, deformation, etc.】

Product Information :

Customer: WINNER

Project Name : P*3

Product Name : High fog lampshade

Product Size : 154*115*99

Product Material : PC black+ clear

Product Weight : 156.2g

Tools Information :

Type: 550T 2K Rotation Table(Reversed)

Hot Runner: YUDO 4 points needle valve

Tool size: 900*1000*692(Z)

Tool weight: 3870KG

Cavity: 1+1

Cycle time : 45S

Make time: 2021.06



2ed: red part

1st-1: white part

1st-2:black part

Product drop: 330

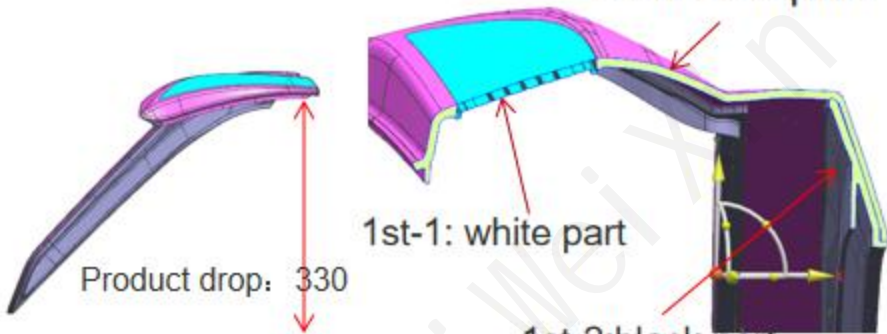

【Type: Vertical Rotation, Separate, 3 Different Colors, Standard】

【Difficulties: Mirror sealing, high product drop, internal voids, avoiding problems such as pressure marks, iron powder, bright lines, cracking, deformation, etc.】

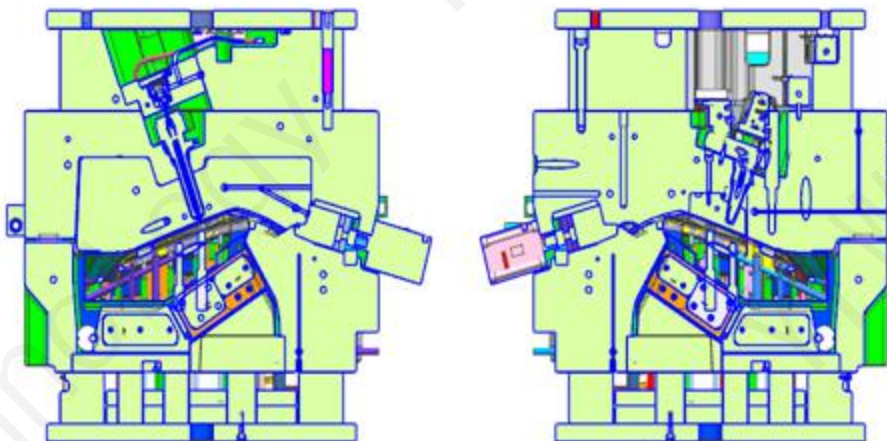

Product Information :

Customer : KOITO

Project Name : P*3B

Product Name : RCL lampshade

Product Size : 338*143*152

Product Material : pmma
black+clear+ red

Product Weight : 313.8g

Tools Information :

Type: 1400T vertical rotary
two-color machine

Hot Runner: master 9 points
needle valve

Tool Size: 1150*700*950(Z) *2

Tool Weight: 4239KG*2

Cavity: 1+1

Cycle time : 45S

Make time: 2019.06

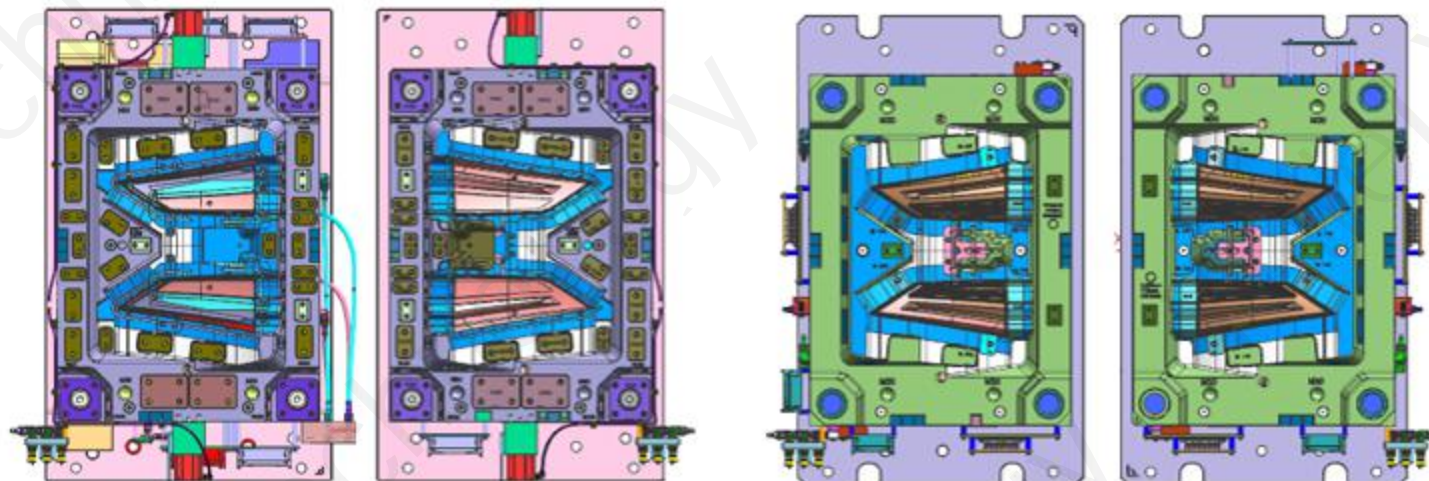
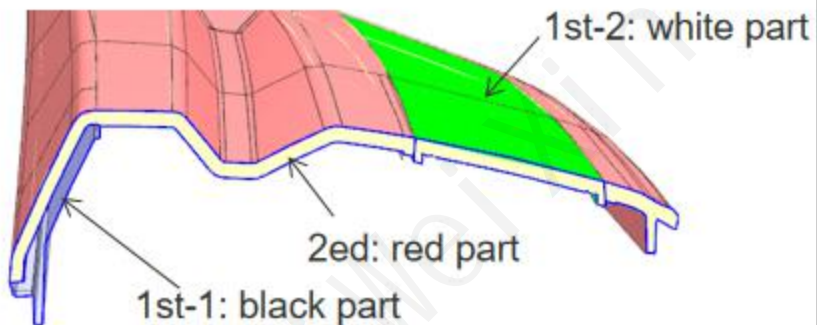

【Type: Vertical Rotation, Separate, 3 Different Colors, Standard】

【Difficulties: Mirror sealing, avoiding problems such as pressure marks, iron powder, bright lines, cracking, deformation, etc.】

Product Information :

Customer : KOITO
 Project Name : P*3B
 Product Name : TL lampshade
 Product Size : 338*143*152
 Product Material : pmma
 black+clear+ red
 Product Weight : 1899.8g

Tools Information :

Type: 14000T vertical rotary two-color machine
 Hot Runner: master 9 points needle valve
 Tool Size: 1150*700*750(Z) *2
 Tool Weight: 3939KG*2
 Cavity: 1+1
 Cycle time : 45S
 Make time : 2019.06

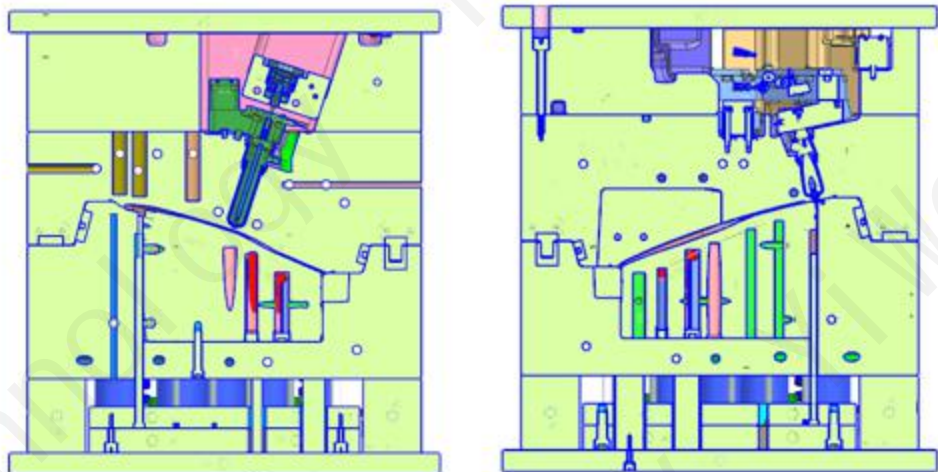

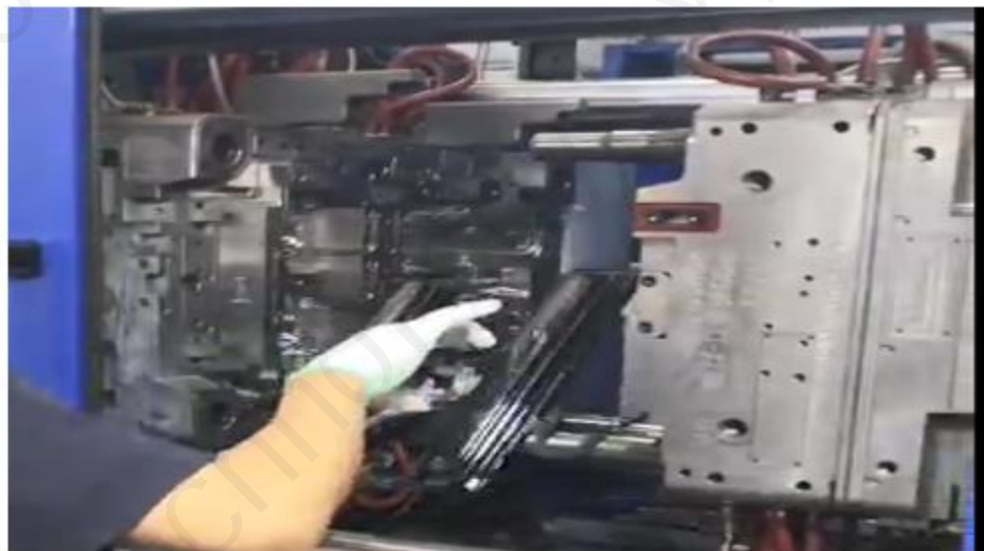
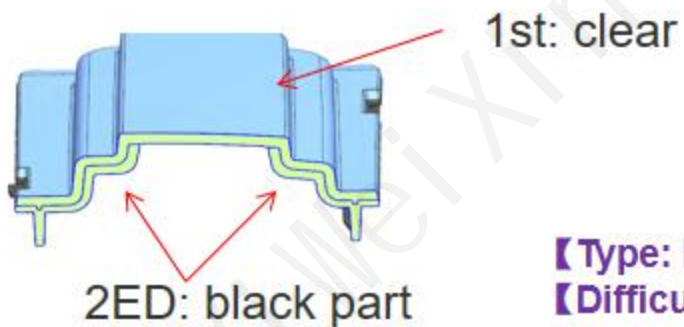

【Type: Horizontal Rotation, Integral, Same Material Different Color, Reversed.】
【Difficulties: Mirror sealing, avoiding problems such as pressure marks, iron powder, bright lines, cracking, deformation, etc.】

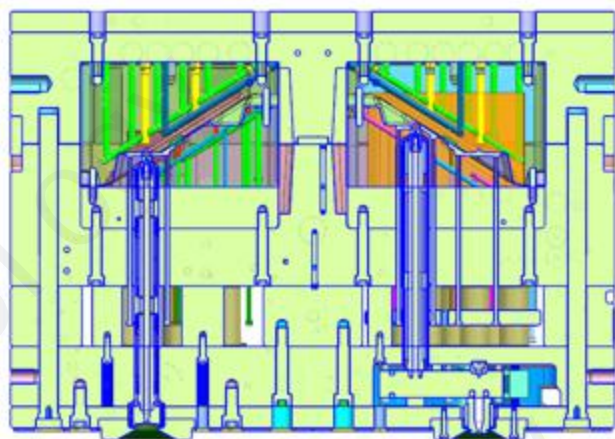

Product Information :
Customer : WINNER
Project Name : P*5
Product Name : High fog lampshade
Product Size : 261*89*168
Product Material : PC black+PC clear
Product Weight : 169.3g

Tools Information :
Type: 550T 2K Rotation Table(Reversed)
Hot Runner: YUDO 4 points needle valve
Tool Size: 1000*850*696(Z)
Tool Weight: 4144KG
Cavity: 1+1
Cycle time : 45S
Make time : 2021.10



2ed: clear part



1st: black part



【Type: Vertical Rotation, Separate, Same Material Different Color, Standard.】
【Difficulties: Mirror sealing, avoiding problems such as pressure marks, iron powder, bright lines, cracking, deformation, etc.】

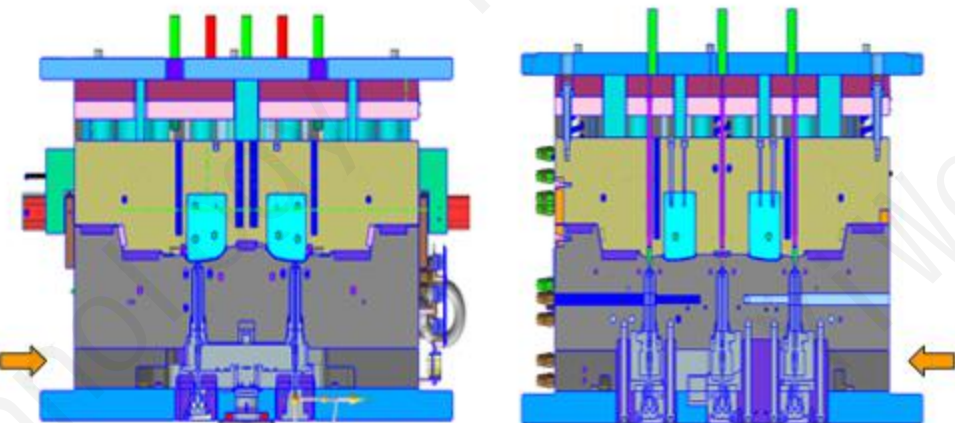

Product Information :

Customer : KOITO
 Project Name : G*5
 Product Name :: TL LENS
 Product Size : 349*280*69
 Product Material : PMMA
 clear/ black
 Product Weight : 186.7g

Tools Information :

Type: 1400T Vertical double color
 Hot Runner: mold masters 5points
 needle valve
 Tool Size: 700*1150*680(Z) *2
 Tool Weight: 3170KG
 Cavity: 1+1
 Cycle time : 45S
 Make time : 2019.06

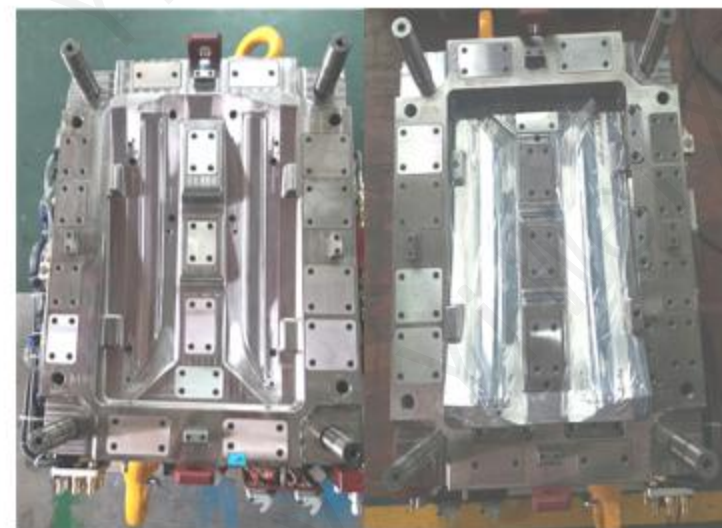
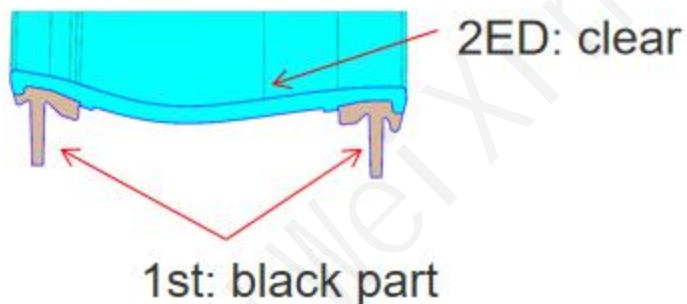

【Type: Vertical Rotation, Separate, Same Material Different Color, Standard.】
【Difficulties: Mirror sealing, avoiding problems such as pressure marks, iron powder, bright lines, cracking, deformation, etc.】

Product Information :

Customer : KOITO
 Project Name : F#0
 Product Name : TL LENS
 Product Size : 600*63*128
 Product Material : PC black
 Product Weight : 160.4

Tools Information :

Type: 1400T, two-color machine
 Hot Runner: masters 8 points
 needle valve
 Tool Size : 1150*700*751*2
 Tool Weight : 4136KG*2
 Cavity: 1+1
 Cycle time : 46S
 Make time: 2022.07

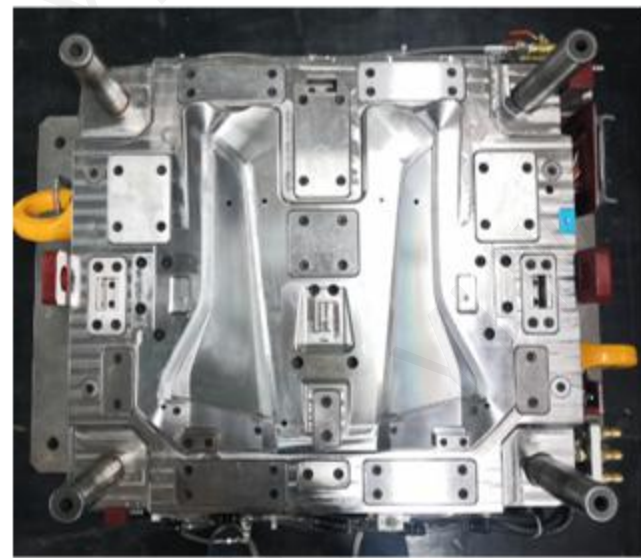
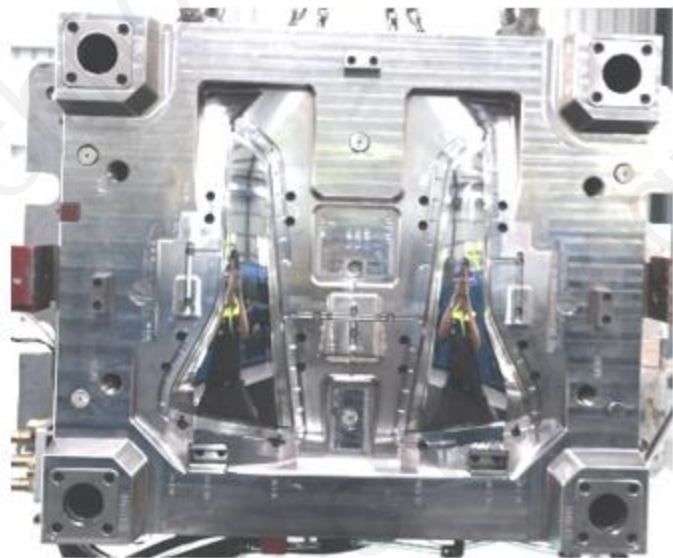
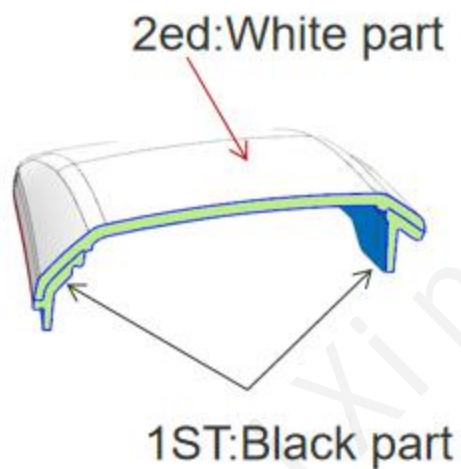

【Type: Vertical Rotation, Separate, Same Material Different Color, Standard.】
【Difficulties: Mirror sealing, avoiding problems such as pressure marks, iron powder, bright lines, cracking, deformation, etc.】

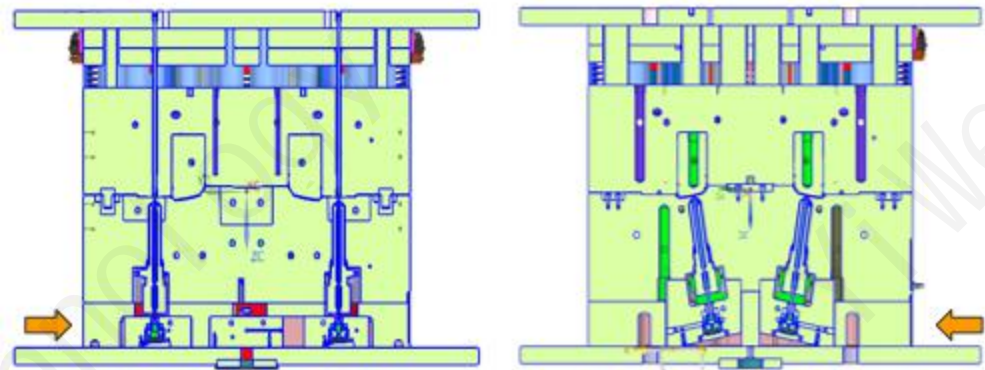

Product Information :
 Customer : KOITO
 Project Name : 2*Y
 Product Name : TL LENS
 Product Size : 436*174*63
 Product Material : PC black
 Product Weight : 173g

Tools Information :
 Type : 1400T, two-color machine
 Hot Runner : masters 5 points
 needle valve
 Tool Size : 1150*700*715*2
 Tool Weight : 3548KG*2
 Cavity : 1+1
 Cycle time : 46S
 Make time : 2021.07

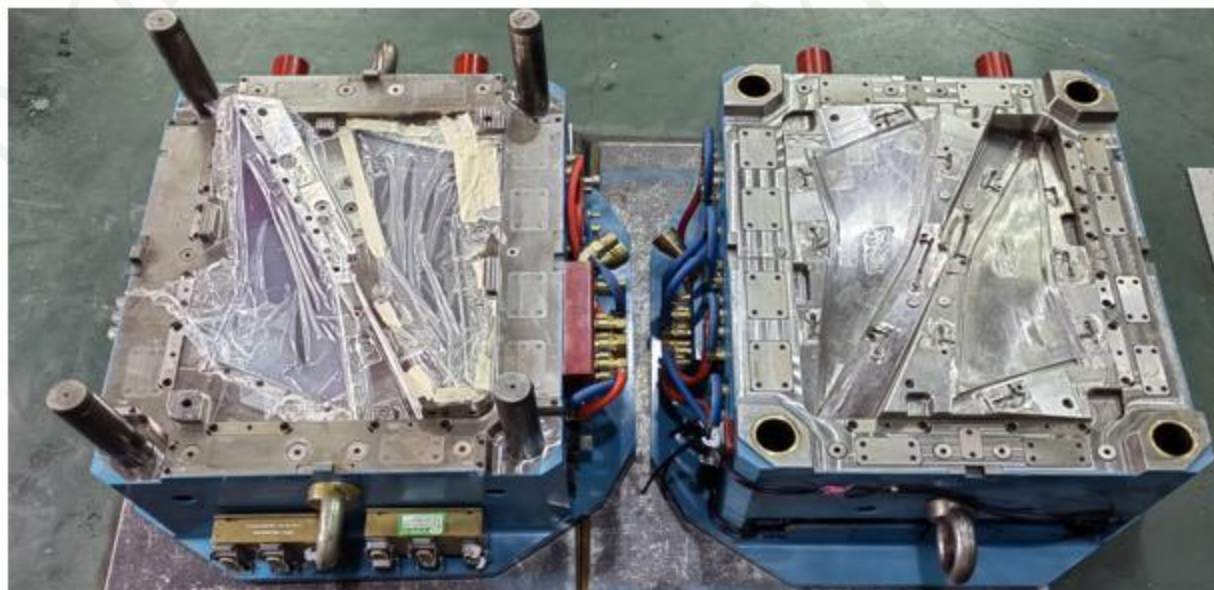
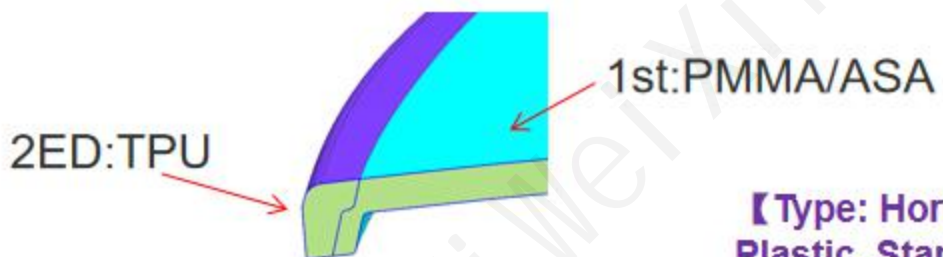

【Type: Horizontal Rotation, Integral, Same Color Different Materials, Soft Plastic Encasing Hard Plastic, Standard】

【Difficulties: Mirror sealing of hard rubber without damaging the soft plastic and preventing the soft plastic from protruding or trapping air.】

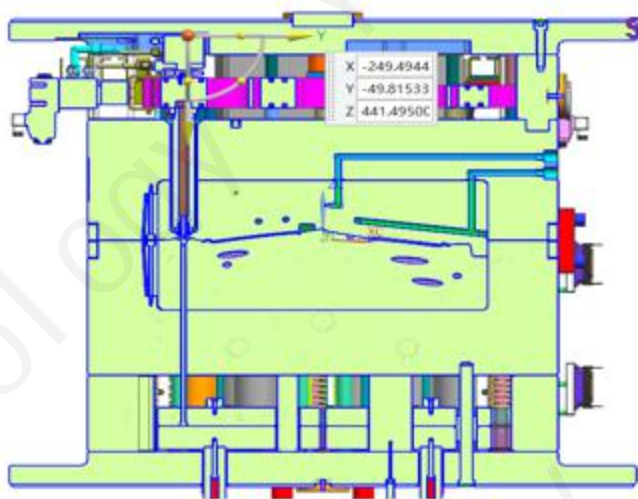

Product Information :

Customer : HangTian
 Project Name : T*9C
 Product Name : Right Rear
 Quarter Panel Body
 Product Size : 766*305*108
 Product Material :
 PC/ABS+TPE black
 Product Weight : 169.3g

Tools Information :

Type : 850T 2K Rotation Table
 Hot Runner : YUDO 8 points
 needle valve
 Tool Size : 1150*1250*1008(Z)
 Tool Weight : 4144KG
 Cavity : 1*1
 Cycle time : 58S
 Make time : 2021.10

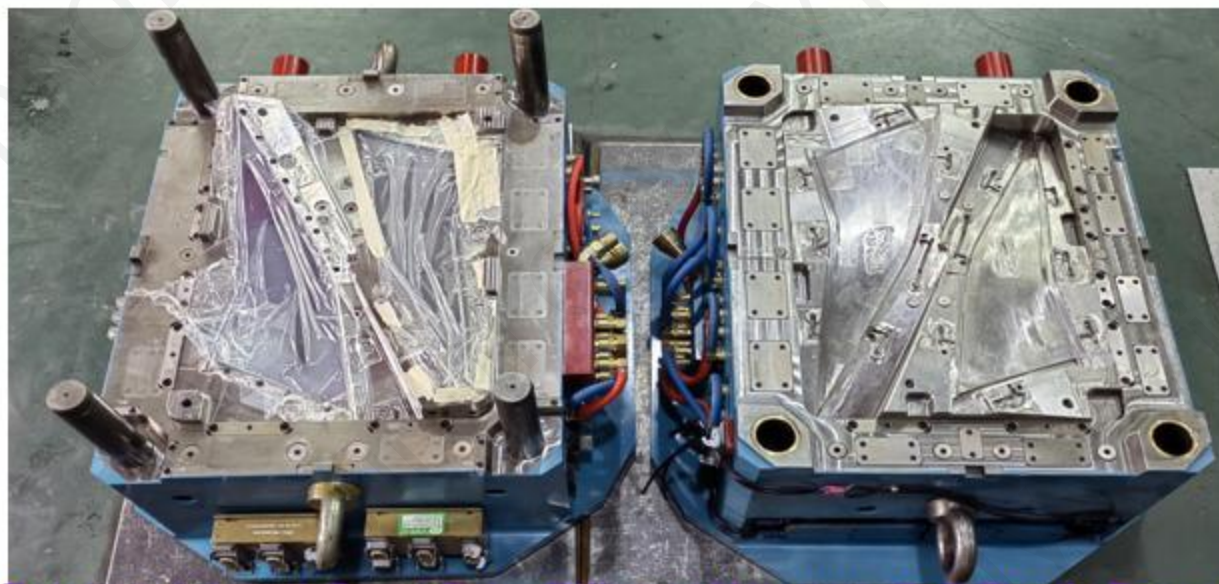
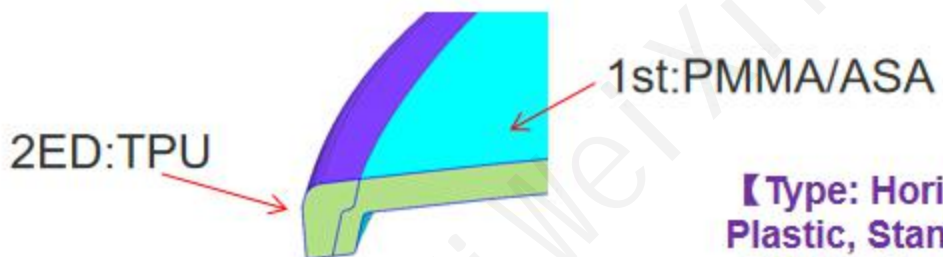

【Type: Horizontal Rotation, Integral, Same Color Different Materials, Soft Plastic Encasing Hard Plastic, Standard】

【Difficulties: Mirror sealing of hard rubber without damaging the soft plastic and preventing the soft plastic from protruding or trapping air.】



Product Information :

Customer : HangTian
 Project Name : T*9C
 Project Name : Right Rear
 Quarter Panel Body
 Product Size : 766*305*108
 Product Material :
 PC/ABS+TPE black
 Product Weight : 169.3g

Tools Information :

Type: 850T 2K Rotation Table
 Hot Runner: YUDO 8 points
 needle valve
 Tool Size : 1150*1250*1008(Z)
 Tool Weight : 4144KG
 Cavity: 1*1
 Cycle time : 58S
 Make Time: 2021.10

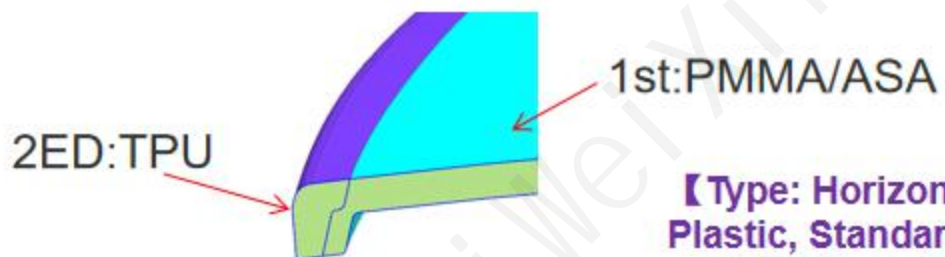

【Type: Horizontal Rotation, Integral, Same Color Different Materials, Soft Plastic Encasing Hard Plastic, Standard】

【Difficulties: Mirror sealing of hard rubber without damaging the soft plastic and preventing the soft plastic from protruding or trapping air..】

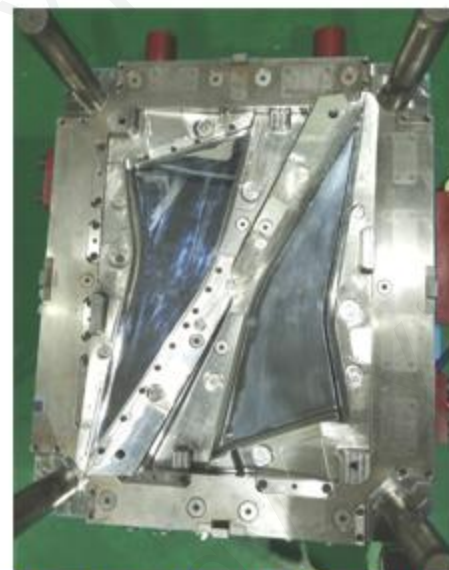

Product Information :

Customer : HangTian
 Project Name : T*9C
 Product Name : Left Rear
 Quarter Panel Body
 Product Size : 766*305*108
 Product Material :
 PC/ABS+TPE black
 Product Weight : 169.3g

Tools Information :

Type: 850T 2K Rotation Table
 Hot Runner : YUDO 8 points
 needle valve
 Tool Size : 1150*1250*1008(Z)
 Tool Weight : 4144KG
 Cavity: 1*1
 Cycle time: 58S
 Make time: 2021.10

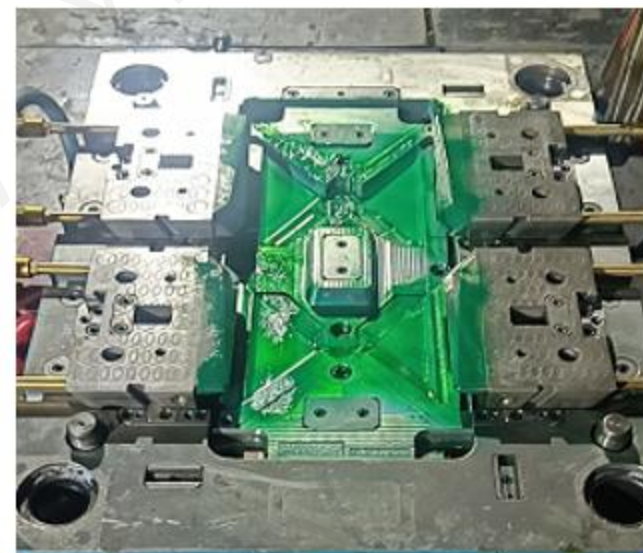
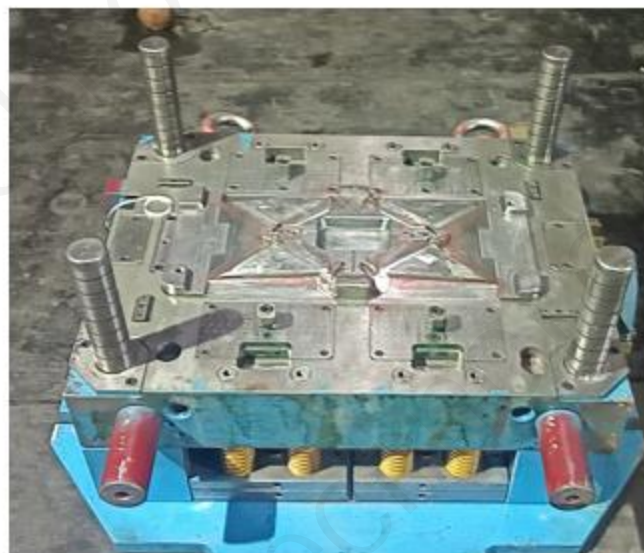
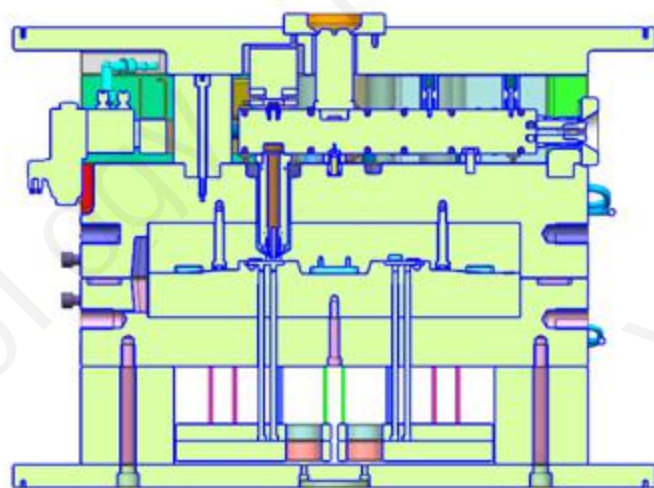
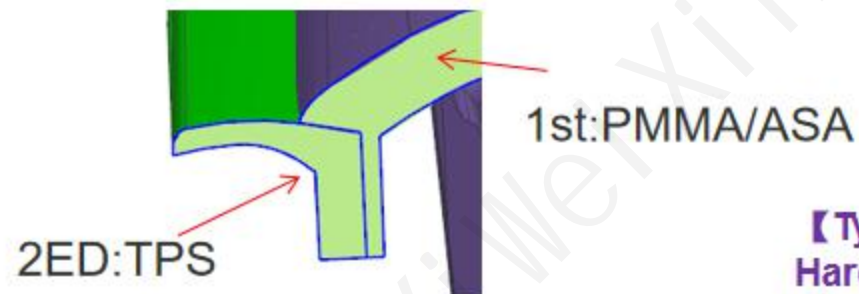

【Type: Horizontal Rotation, Integral, Same Color Different Materials, Soft Plastic Encasing Hard Plastic, Standard】

【Difficulties: Mirror sealing of hard rubber without damaging the soft plastic and preventing the soft plastic from protruding or trapping air】

Product Information :

Customer : HangTian
 Project Name : M*E
 Product Name : Triangle Plate
 Product Size : 176*76*29
 Product Material :
 PMMA/ASA+TPS black
 Product Weight : 169.3g

Tools Information :
 Type: 500T 2K Rotation Table
 Hot Runner : YUDO 3 points
 needle valve
 Tool Size : 950*850*680(Z)
 Tool Weight : 2210KG
 Cavity: 1+1
 Cycle time : 52S
 Make time: 2021.06



2ED: black part

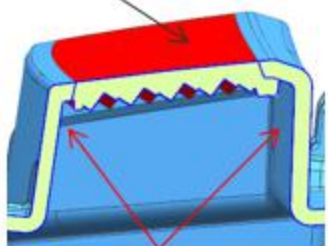

1st: red part

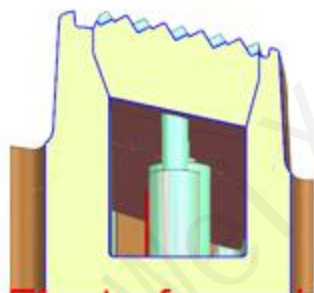

Electroformed kernels



Reflecting surface

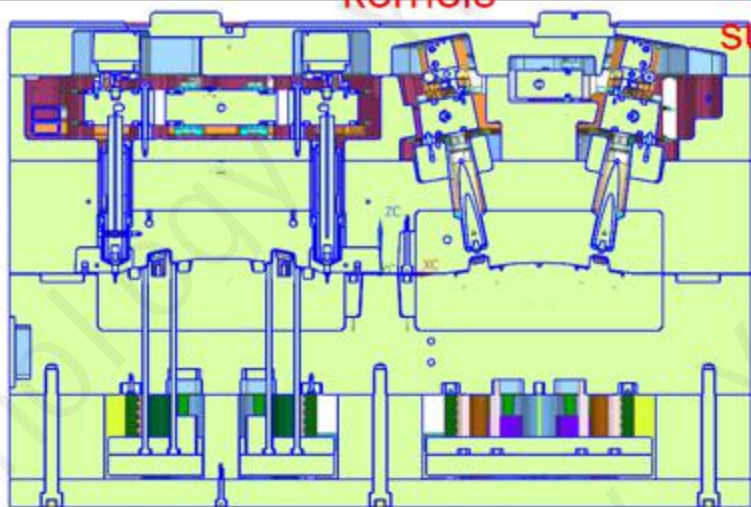

【Type: Horizontal Rotation, Integral, Same Material Same Color, electroform, Self-reflective Function, Standard】

【Difficulties: Mirror sealing without any imperfections such as pressure marks, iron powder, bright lines, cracking, or distortion during mass production.】

Product Information :

Customer : WNNER
 Project Name : B*1E
 Product Name :: Turn signal with reverse Lampshade
 Product Size : 342*74*54
 Product Material : ABS black+PMMA red
 Product Weight : 91.7g

Tools Information :

Type: 550T, 2K Rotation Table
 Hot Runner: 恒道 6 points needle valve
 Tool Size : 1050*850*687
 Tool Weight : 4513KG
 Cavity: 1+1
 Cycle time : 58S
 Make time: 2022.12



2ED:PMMA
Red clear

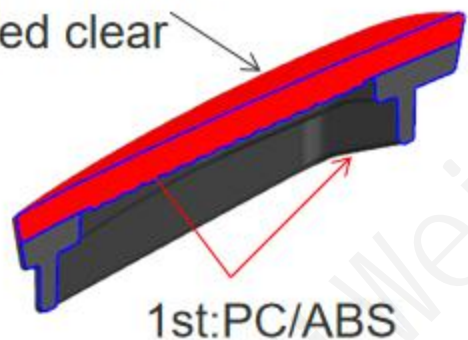

1st:PC/ABS

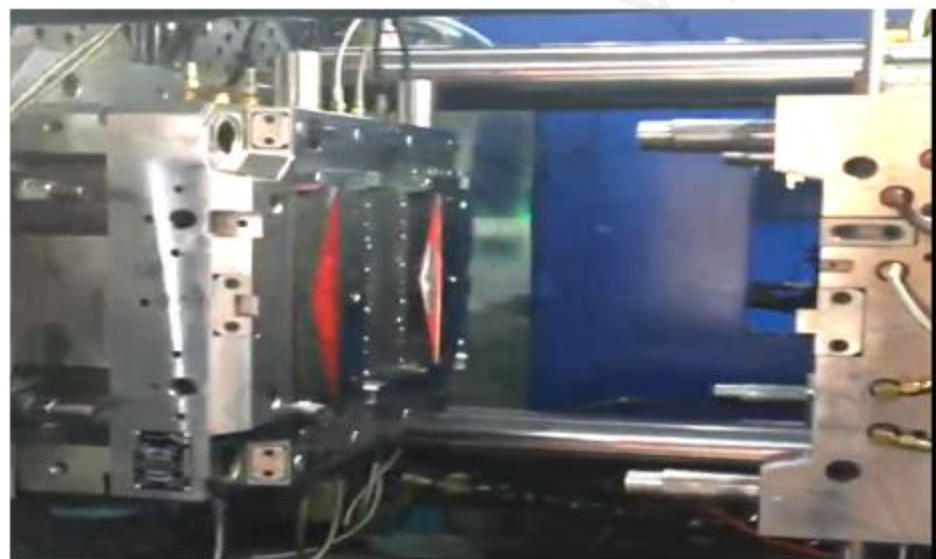

【Type: Horizontal Rotation, Integral, Different Materials Different Colors, Pattern with Optical Requirements, Standard】

【Difficulties: Mirror sealing without any imperfections such as pressure marks, iron powder, bright lines, cracking, or distortion during mass production.】

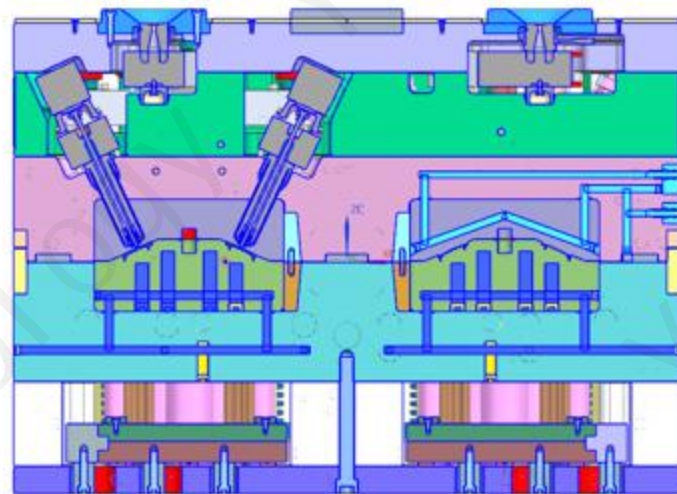

Product Information :

Customer : WINNER

Project Name : C03

Product Name : High brake light lampshade

Product Size : 370*44*30

Product Material :

PC/ABS+PMMA red

Product Weight : 53.5g

Tools Information :

Type: 550T, 2K Rotation

TableHot Runner: 恒道 6 points needle valve

Tool Size : 950*850*770

Tool Weight : 4365KG

Cavity: 1+1

Cycle time : 46S

Make time : 2022.08

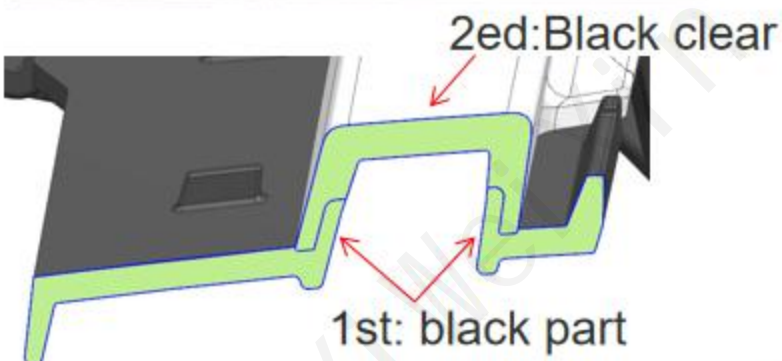

【Type: Horizontal Rotation, Integral, Same Color Different Materials, Standard】
【Difficulties: Preventing color mixing when white parts flow into black parts, avoiding pressure marks and mirror deformation on the appearance parts.】

Product Information :
 Customer : VALEO
 Project Name : C*1E
 Product Name : Door Lamp Lens
 Product Size : 332*121*84
 Product Material : PC black+PMMA clear
 Product Weight : 71.7g

Tools Information :
 Type : 1000T, 2K Rotation Table
 Hot Runner: HRS 5 points needle valve
 Tool size: 1000*980*779
 Tool Weight : 3850KG
 Cavity: 1+1
 Cycle time : 52S
 Make time : 2022.12

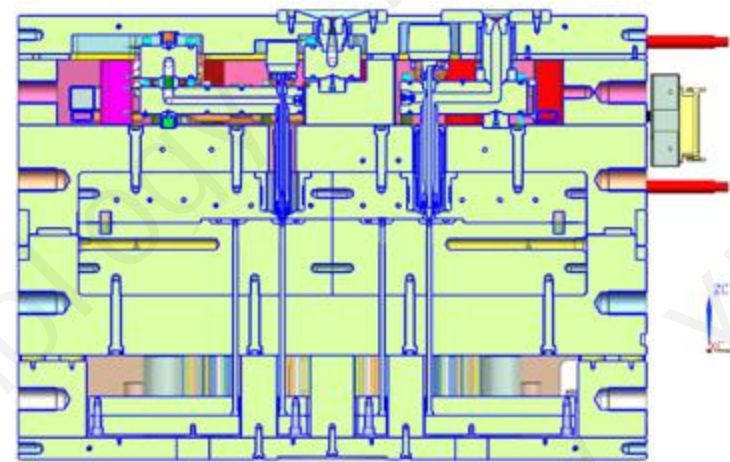

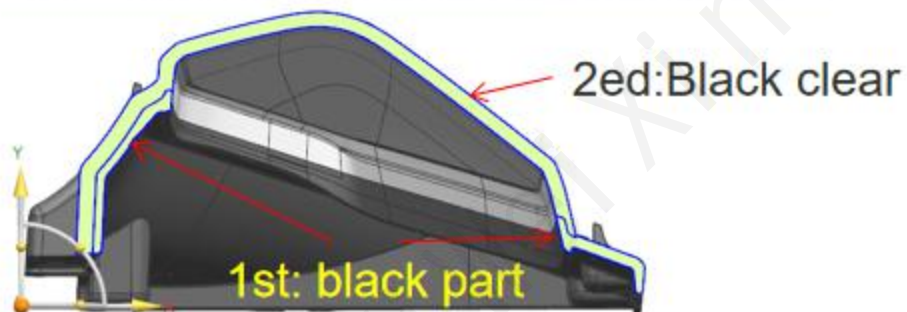

【Type: Horizontal Rotation, Integral, Same Color Different Materials, Standard】
【Difficulties: Preventing color mixing when white parts flow into black parts, avoiding pressure marks and mirror deformation on the appearance parts】

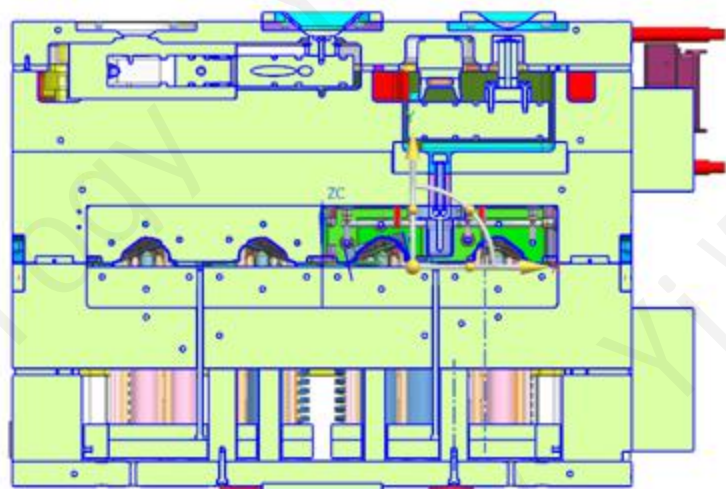

Product Information :

Customer : VALEO
 Project Name : C*1E
 Product Name : Console Lens
 Product Size : 338*111*47
 Product Material : PC black
 +PMMA clear
 Product Weight : 133.4g

Tools Information :

Type: 1000T, Rotation Table
 Hot Runner: HRS 5points
 needle valve
 Tool size: 1000*980*751
 Tool Weight : 3700KG
 Cavity: 1*2
 Cycle time : 52S
 Make time : 2022.12



1st: Red Part



【Type: Horizontal Rotation, Integral , Same Materials, Different color,standard】
【Difficulties: Mirror sealing, avoiding problems such as pressure marks, iron powder, bright lines, cracking, deformation, etc.】

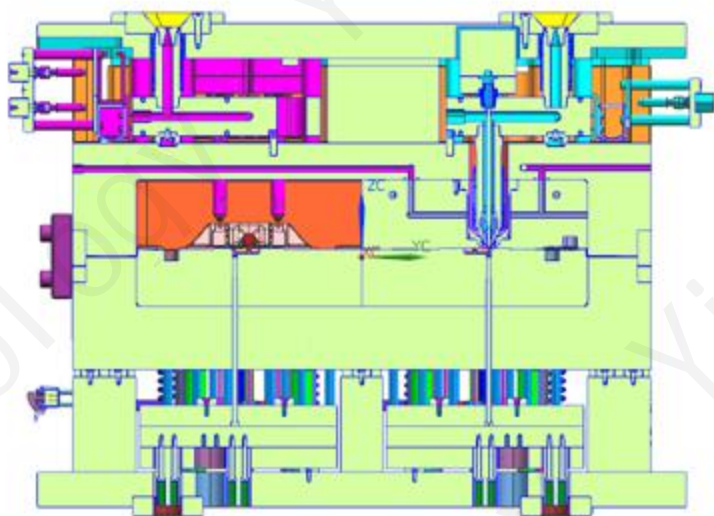

Product Information :

Customer : WeiGao
 Project Name : A19
 Product Name : Front brake lampshade
 Product Size : 211*98*58
 Product Material : PMMA black+red
 Product Weight : 79.7g

Tools Information :

Type: 450T,Rotation Table
 Hot Runner: YUDO 5 points needle valve
 Tool size: 970*640*687
 Tool Weight : 2170KG
 Cavity: 1*2
 Cycle time : 38S
 Make time : 2023.09

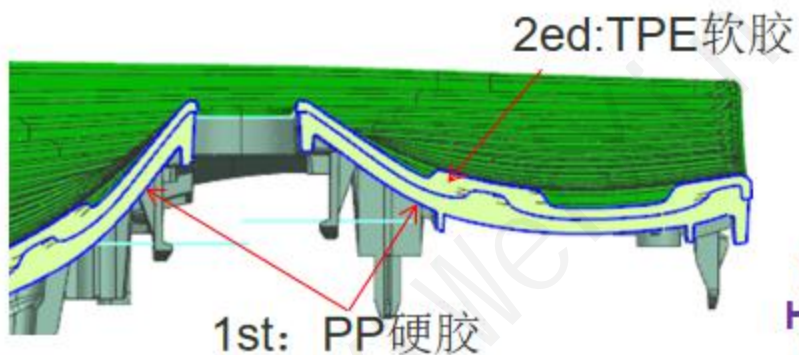

【Type: Opposite Injection, Separate, Same Color Different Materials, Soft Plastic Covering Hard Plastic, Standard】

【Difficulties: Large area coverage of soft rubber over hard rubber, ensuring good flow ability without any trapped air or flashing issues.】

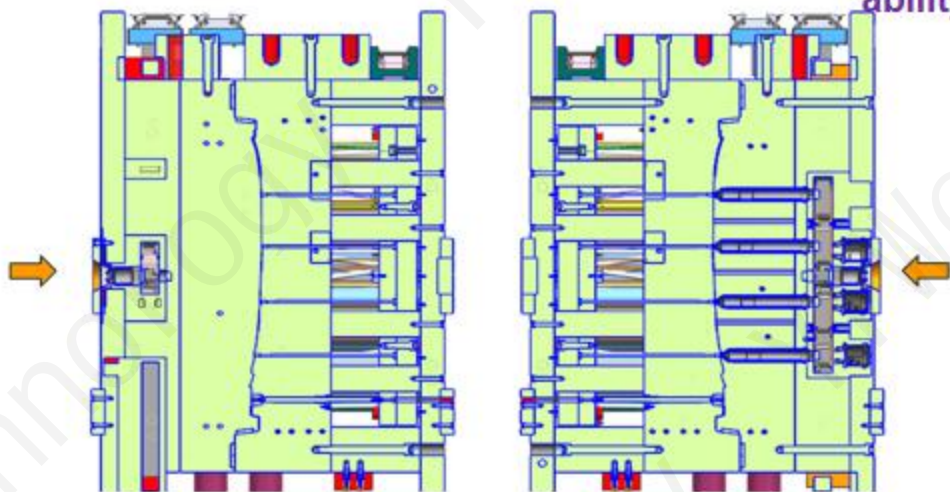

Product Information :

Customer : ShuangYing
 Product Name : E12
 Product Name : Front Door Trim Panel
 Product Size : 860*330*133
 Product Material : PP+TPE
 Product Weight : 1455.6g

Tools Information :

Type: 1800T, Opposite 2K Spin Stack
 Hot Runner: 8+19 points needle valve
 Tool size: 1700*1530*920*2
 Tool Weight : 13784KG*2
 Cavity: 1+1
 Cycle time : 68S
 Make time : 2022.12



2ed:TPE soft material

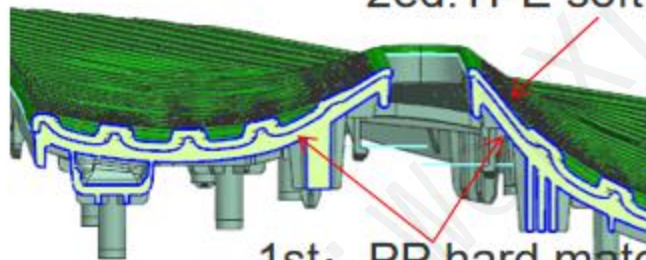

1st: PP hard material



【Type: Opposite Injection, Separate, Same Color Different Materials, Soft Plastic Covering Hard Plastic, Standard】

【 Difficulties: Large area coverage of soft rubber over hard rubber, ensuring good flow ability without any trapped air or flashing issues.】

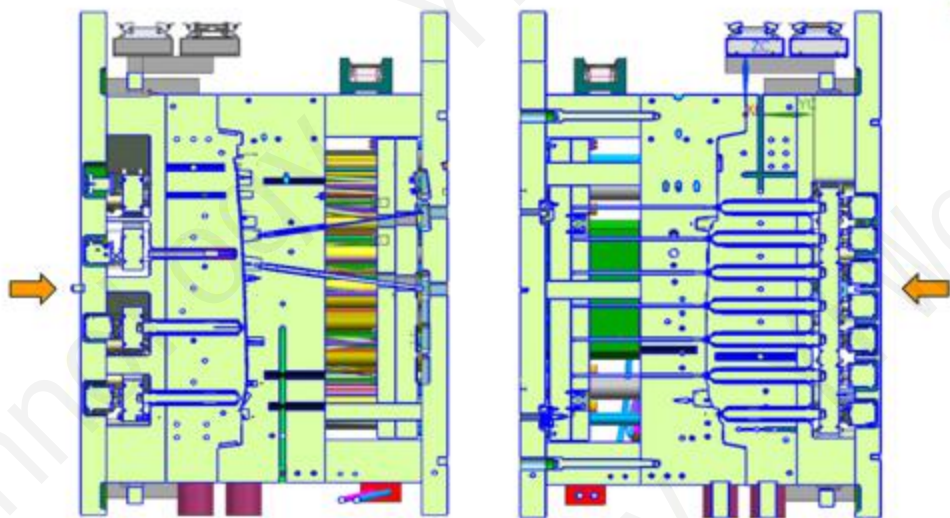

Product Information :

Customer : ShuangYing
 Product Name : E12
 Product Name : Front Door Trim Panel
 Product Size : 920*420*110
 Product Material : PP+TPE
 Product Weight : 1398.5g

Tools Information :

Type: 1800T, Opposite 2K Spin Stack
 Hot Runner: 8+19 points needle valve
 Tool size: 1700*1530*940*2
 Tool Weight : 13899KG*2
 Cavity: 1+1
 Cycle time : 68S
 Make time : 2022.12

2. 1K Lampshade Tools

Feature:

- 1, High Gloss
- 2, Optical Requirement

- 1. High-quality steel material is required.
- 2. Accurate temperature control for hot runners
- 3. Uniform and stable mold temperature distribution
- 4. High-speed and ultra-precision tooling, achieving high machining accuracy
- 5. Precise mold fitting requirements
- 6. High demands for polishing techniques

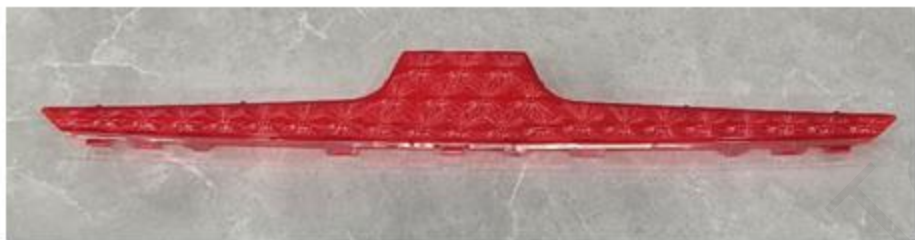

Frontal pattern.

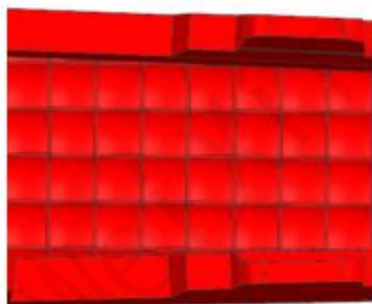

Backside pattern



【Highlight: Both the front and back molds have optical surfaces, requiring the use of minimum machining tools with an R0.1 radius and high mold temperature.】

【Difficulties: Passing optical testing without any issues such as iron powder contamination, scratches, deformation of optical surfaces, or mirror distortion.】

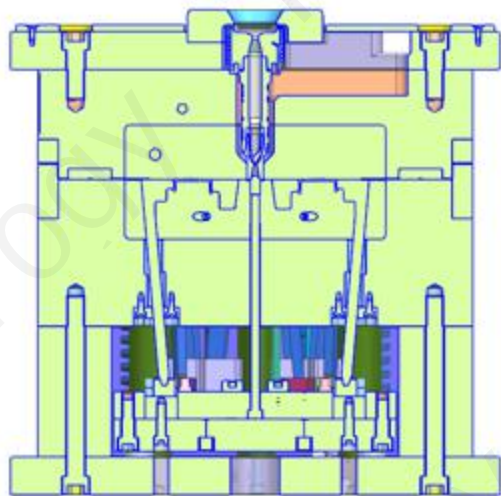

Product Information :

Customer : WINNER
 Product Name : P*2
 Product Name : High brake light inner lens
 Product Size : 310*35*20
 Product Material : PC红色
 Product Weight : 23.3g

Tools Information :

Type: 160T monochrome Hot Runner: YUDO Single-point open nozzle
 Tool size: 450*550*432(Z)
 Tool Weight : 6398KG
 Cavity: 1*2
 Cycle time : 35S
 Make time : 2022.04

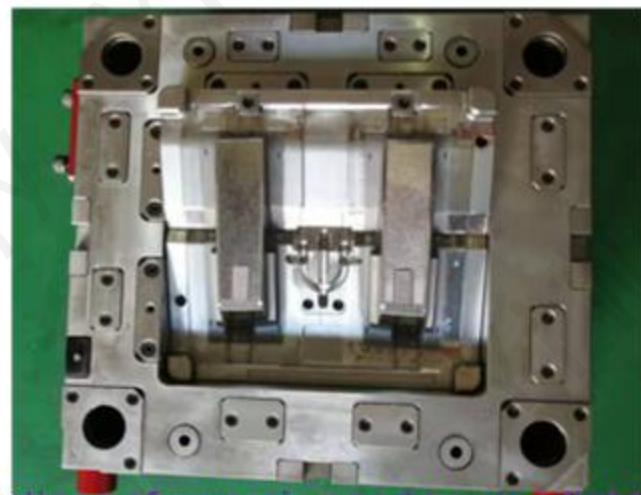
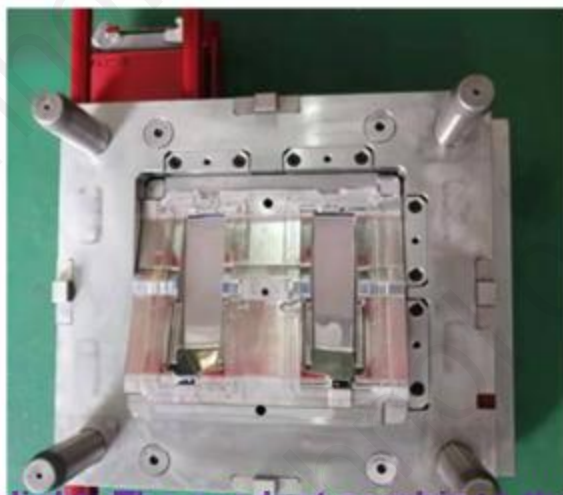
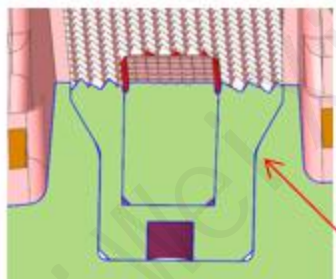
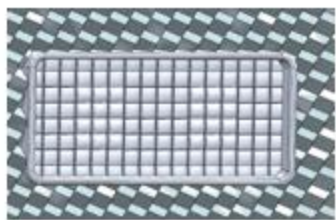
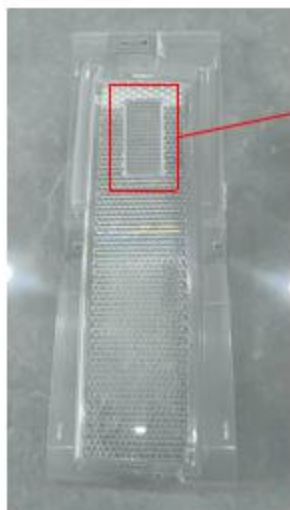

【Highlight: The product combines the functions of reversing and turning lights, with an electrically cast emblem on the back mold. The turning function is achieved through the reflective surface of the emblem, while the reversing function is achieved through the optical surface CNC machining using minimum tools with an R0.1 radius.】

【Difficulties: Achieving two optical functions in one product requires strict control of optical surface machining and molding.】

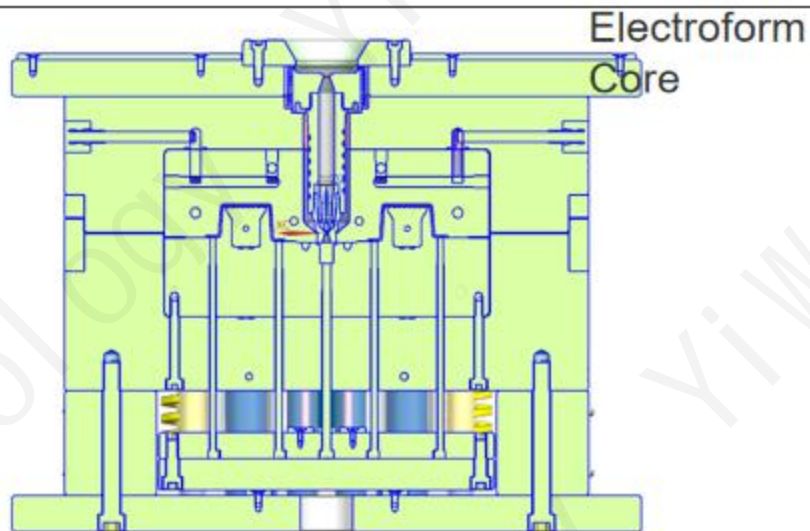

Product Information :

Customer : WINNER
 Product Name : B*6
 Product Name : Reverse
 Lampshade with Backup Light
 Product Size : 205*78*52
 Product Material : PC clear
 Product Weight : 76.3g

Tools Information :

Type: 320T 1K
 Hot Runner: YUDO 1 points
 needle valve
 Tool size: 600*450*457(Z)
 Tool Weight : 868KG
 Cavity: 1+1
 Cycle time : 38S
 Make time : 2022.04

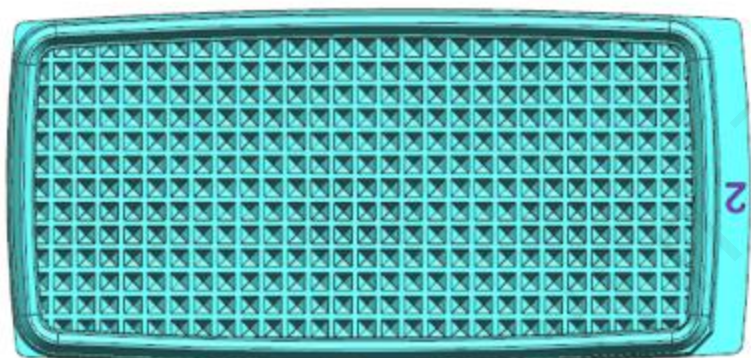

【Highlights: The front and back molds have optical surfaces, requiring the use of minimum machining tools with an R0.1 radius and high mold temperature.】

【Challenges: Need to pass optical testing without any issues such as iron powder contamination, scratches, deformation of optical surfaces, or mirror distortion.】

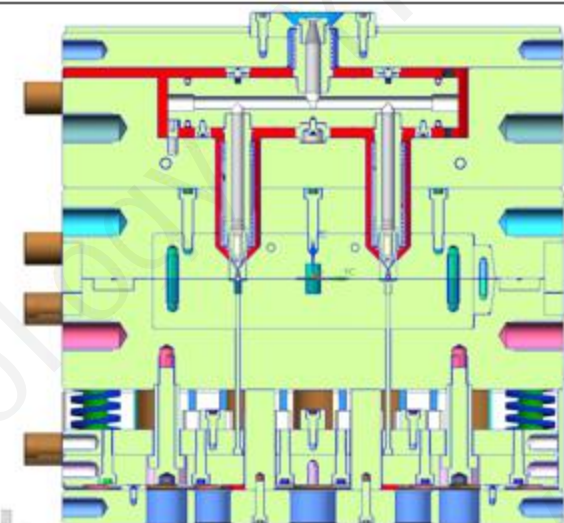

Product Information :

Customer : WINNER
 Product Name : SA*9
 Product Name : Door lampshade
 Product Size : 37*17*4
 Product Material : PC clear
 Product Weight : 16g

Tools Information :

Type: 160T 1K
 Hot Runner: YUDO 2 points pin
 Tool size: 500*450*496(Z)
 Tool Weight : 770KG
 Cavity: 1*8
 Cycle time : 35S
 Make time : 2022.09



【Highlights: The front and back molds have optical surfaces, requiring the use of minimum machining tools with an R0.2 radius and high mold temperature.】

【Challenges: Need to pass optical testing without any issues such as iron powder contamination, scratches, deformation of optical surfaces, or mirror distortion.】

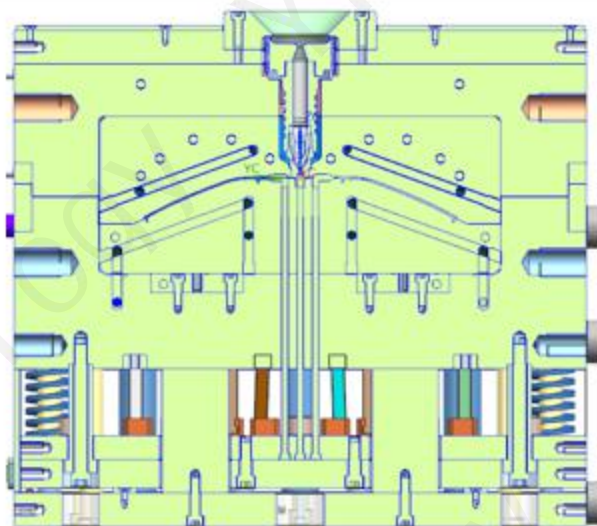

Product Information :

Customer : WINNER
 Product Name : A07
 Product Name : Rear fog lampshade
 Product Size : 128*125*70
 Product Material : PMMA red
 Product Weight : 69.8g

Tools Information :

Type: 320T,1K
 Hot Runner: YUDO 1 points needle valve
 Tool size: 600*450*525
 Tool Weight : 965KG
 Cavity: 1*2
 Cycle time : 38S
 Make time : 2021.12

3. Thick-Walled Lens Tools

Feature:

1. High gloss finish required on both front and back molds.
2. Optical requirements need to be met.
3. Thick wall sections are present.

1. High-quality steel material is required.
2. Precise temperature control is needed for the hot runners.
3. Uniform and stable mold temperature distribution is necessary.
4. High-speed and high-precision machining is required.
5. Precise mold fitting is necessary.
6. High demands for polishing techniques.
7. Long cycle time is expected.



Max Thickness:
20*40mm

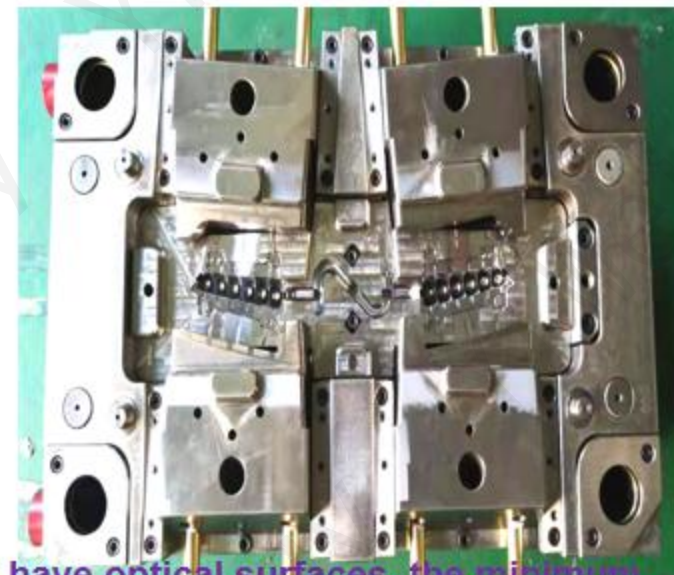

【 Highlights: The front and rear molds have optical surfaces, the minimum processing tool R0.1, high mold temperature, and thick meat , Cycle time : long】
【 Difficulties: Passing optical testing without any issues such as iron powder contamination, scratches, deformation of optical surfaces, or mirror distortion.】

Product Information :

Customer : WNNER
Product Name : B*1E
Product Name : The turn signal brings back the mirror lens
Product Size : 91*54*44
Product Material : PC clear
Product Weight :

Tools Information :

Type: 160T, monochrome machine
Hot Runner: YUDO 1 points needle valve
Tool size: 550*400*437
Tool Weight : 665KG
Cavity: 1+1
Cycle time : 200S
Make time : 2022.05

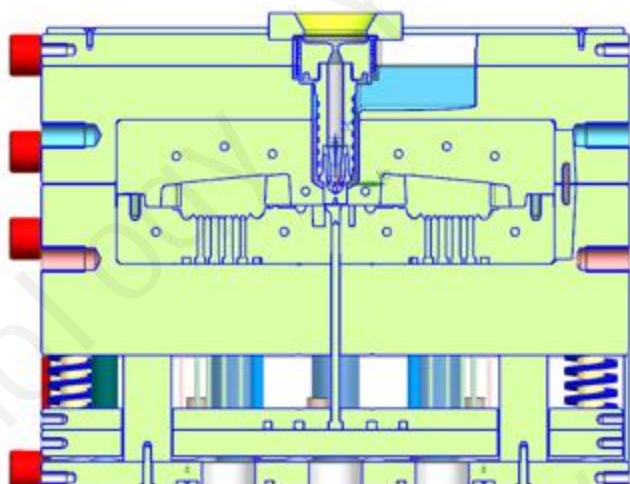

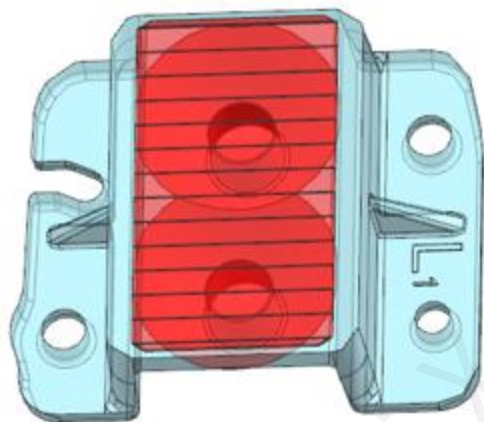

Max Thickness: 12mm

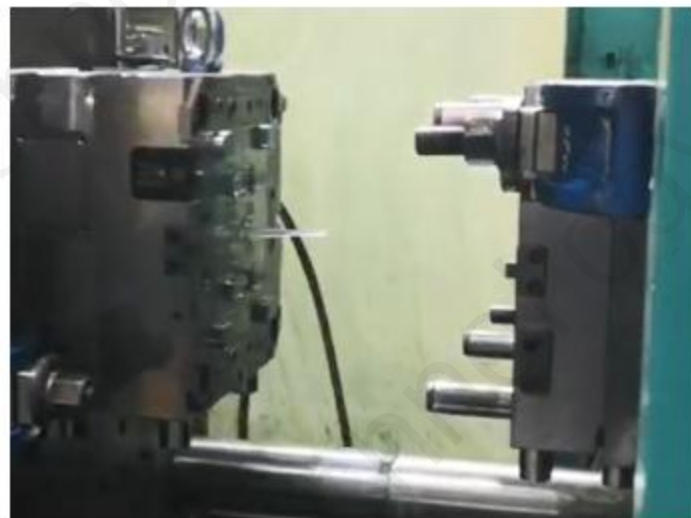

【Highlights: The front and back molds have optical surfaces, requiring the use of minimum machining tools with an R0.2 radius. High mold temperature and thick wall sections are present, resulting in a long cycle time.】

【Challenges: Need to pass optical testing without any issues such as iron powder contamination, scratches, deformation of optical surfaces, or mirror distortion.】

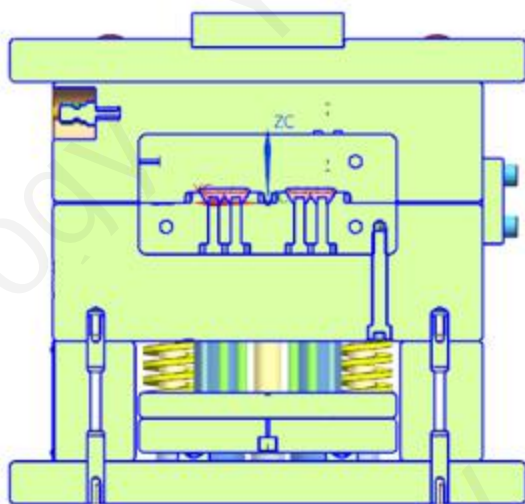

Product Information :

Customer : WINNER
 Product Name : B16
 Product Name : Rear fog lamp inner lens
 Product Size : 31*28*10
 Product Material : PC clear
 Product Weight : 12g

Tools Information :

Type: 160T,1K
 Hot Runner: Cold Runner
 Tool size: 300*270*270
 Tool Weight : 150KG
 Cavity: 2+2
 Cycle time : 52S
 Make time : 2022.04

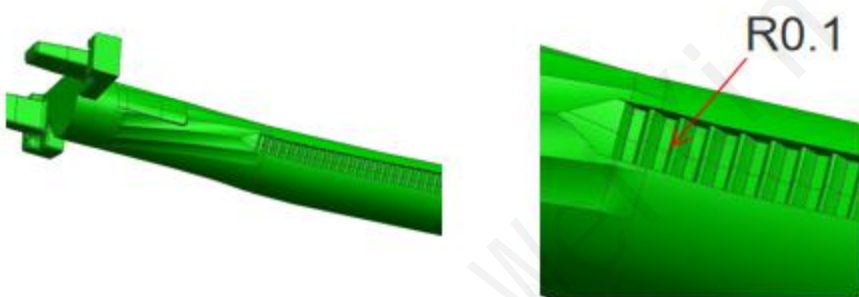

【Highlights: The product features optical surfaces, requiring the use of minimum machining tools with an R0.1 radius and high mold temperature.】

【Challenges: The product needs to pass optical testing without any issues such as iron powder contamination, scratches, deformation of optical surfaces, or mirror distortion.】

Product Information :
 Customer : VALEO
 Product Name : B*1E
 Product Name : LIGHT GUIDE
 Product Size : 353*14*32
 Product Material : PMMA clear
 Product Weight : 16.1g

Tools Information :
 Type: 850T, 1K
 Hot Runner: Hot-Tip
 Tool size: 1000*560*570
 Tool Weight : 1688KG
 Cavity: 1*2
 Cycle time : 48S
 Make time : 2022.04

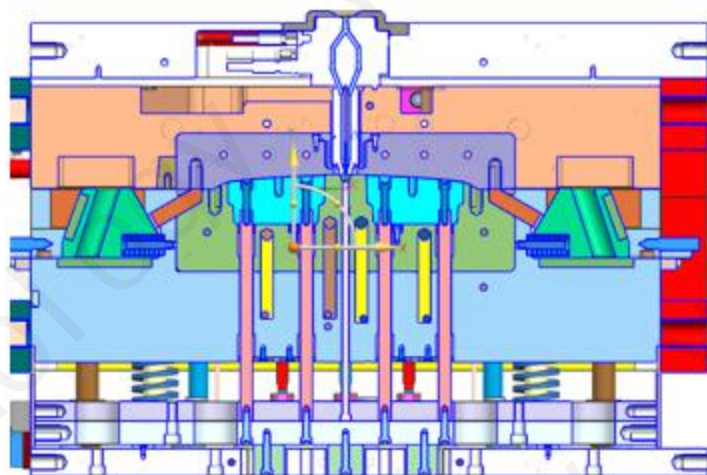

4. Electroplating and High-gloss Tools

Feature:

1. High gloss finish required on the cavity
2. Some parts have optical requirements that need to be met.

1. High-quality steel material is required.
2. Precise temperature control is needed for the hot runners.
3. Uniform and stable mold temperature distribution is necessary.
4. High-speed and high-precision machining is required.
5. Precise mold fitting is necessary.
6. High demands for polishing techniques.



Optical Faces, Primer free electroplating.

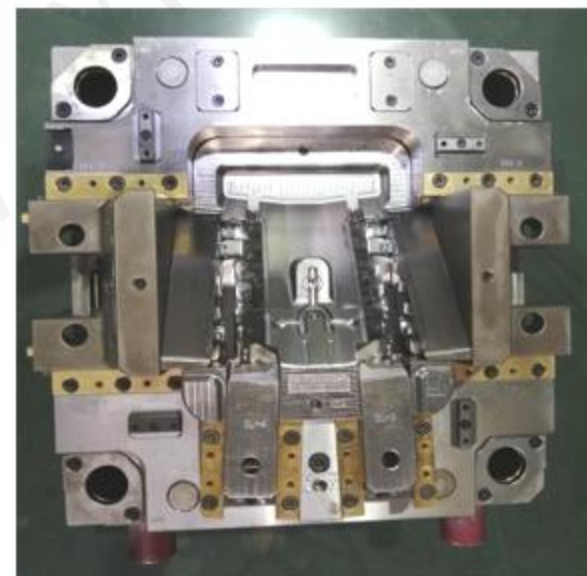

【Highlights: The cavity has optical surfaces, requiring the use of minimum machining tools with an R0.2 radius and high mold temperature.】

【The product needs to pass optical testing without any issues such as iron powder contamination, scratches, deformation of optical surfaces, or mirror distortion.】

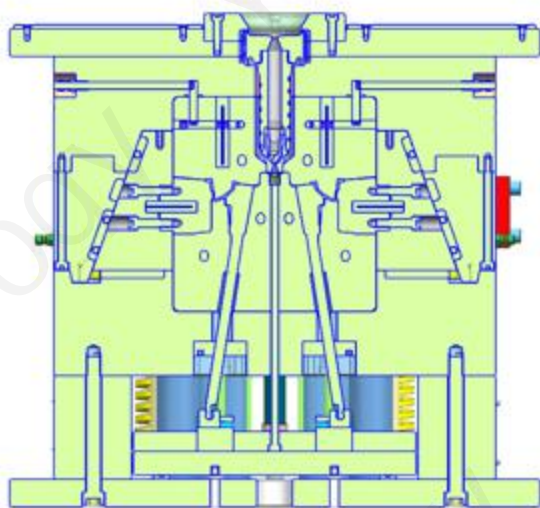

Product Information :

Customer : WINNER
 Product Name : B*6
 Product Name Front fog lamp reflector
 Product Size : 147*42*159
 Product Material : PC High-gloss black
 Product Weight : 46.2g

Tools Information :

Type: 320T 1K
 Hot Runner: YUDO 1 points needle valve
 Tool size: 600*500*660(Z)
 Tool Weight : 1270KG
 Cavity: 1+1
 Cycle time : 38S
 Make time : 2022.04



Primer free electroplating.

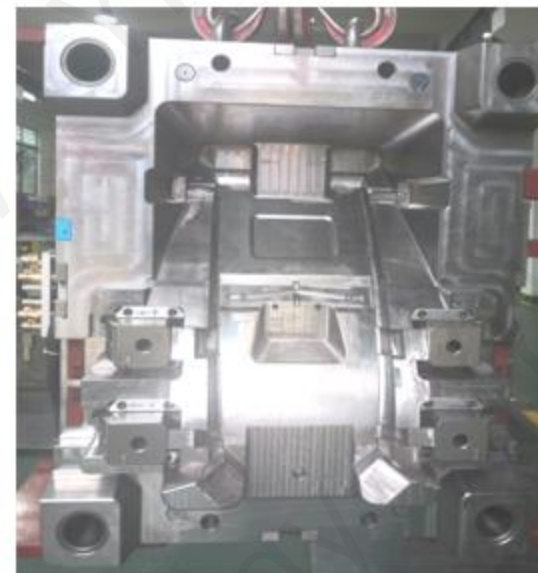

【Highlights: The cavity requires partial mirror polishing, with Primer free electroplating, and high mold temperature】

【Challenges: It is important to avoid issues such as iron powder contamination, scratches, and mirror distortion.】

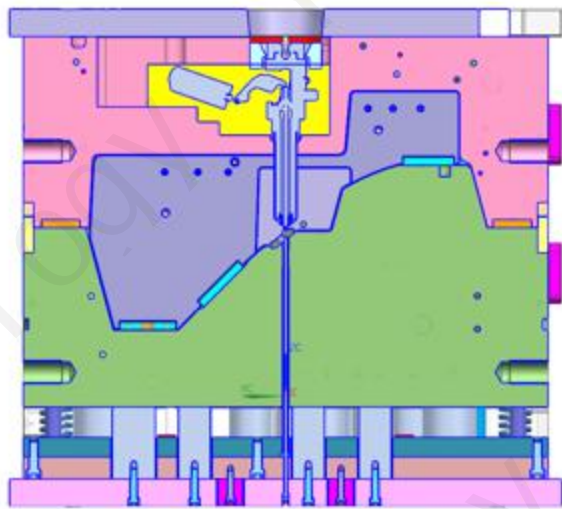

Product Information :

Customer : KOITO
 Product Name : D*2
 Product Name : HL EXT
 Product Size : 527*45*405
 Product Material : PC black
 Product Weight : 96.5g

Tools Information :

Type: 850T 1K
 Hot Runner: masters 1 points
 needle valve
 Tool size: 850*1000*950(Z)
 Tool Weight : 4990KG
 Cavity: 1+1
 Cycle time : 42S
 Make time : 2021.05

Primer free electroplating

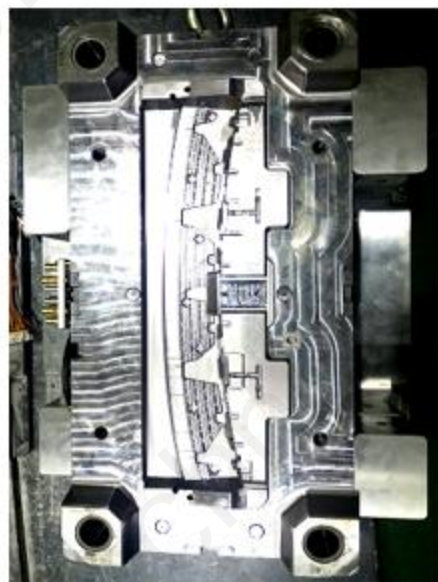
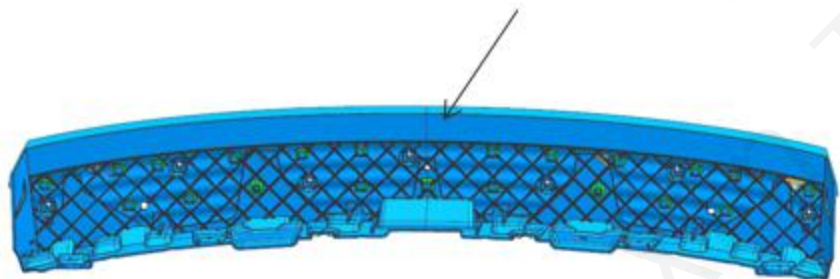

【Highlights: The cavity requires partial mirror polishing, with Primer free electroplating, and high mold temperature】

【Challenges: It is important to avoid issues such as iron powder contamination, scratches, and mirror distortion.】

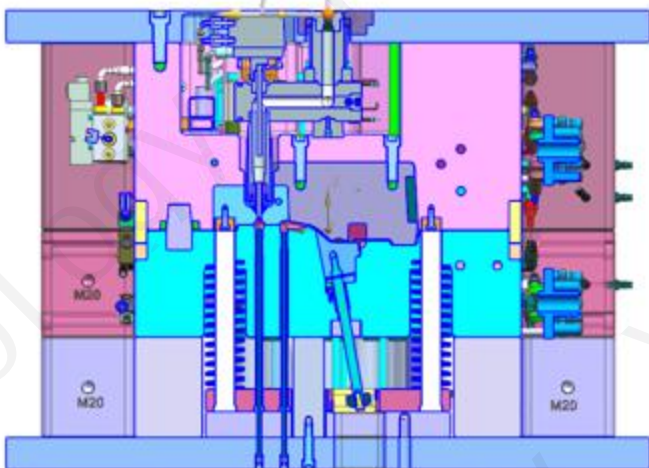

Product Information :

Customer : KOITO

Product Name : E*8

Product Name : HL EXT

Product Size : 883*175*74

Product Material : PC Black

Product Weight :

Tools Information :

Type: 850T, 1K

Hot Runner: masters 3 Valve
Nozzle

Tool size: 800*1200*711

Tool Weight : 4217KG

Cavity: 1*1

Cycle time : 42S

Make time : 2021.10



Optical Faces, Primer free electroplating

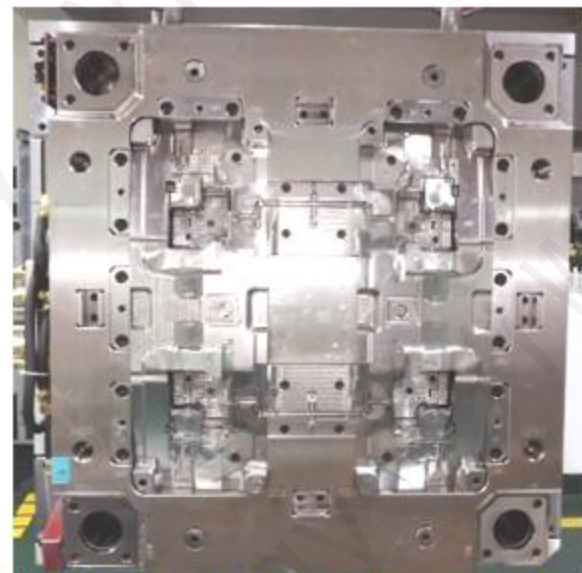

【Highlights: The cavity has optical surfaces, requiring the use of minimum machining tools with an R0.2 radius and high mold temperature.】

【The product needs to pass optical testing without any issues such as iron powder contamination, scratches, deformation of optical surfaces, or mirror distortion.】

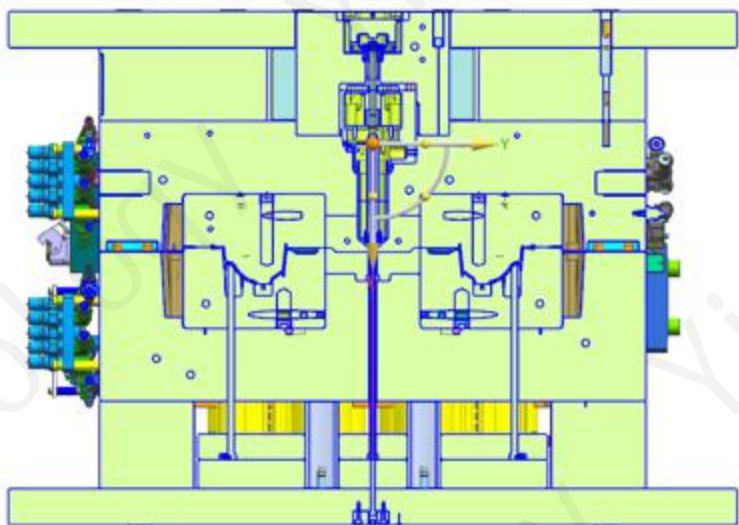

Product Information :

Customer : KOITO
 Product Name : 3*1D
 Product Name : TL BG REF
 Product Size : 191*98*96
 Product Material : PC grey
 Product Weight : 513.3g

Tools Information :

Type: 850T, monochrome machine
 Hot Runner: masters 2 points needle valve
 Tool size: 1000*1000*705
 Tool Weight : 3410KG
 Cavity: 2+2
 Cycle time : 42S
 Make time : 2023.04



Primer free electroplating

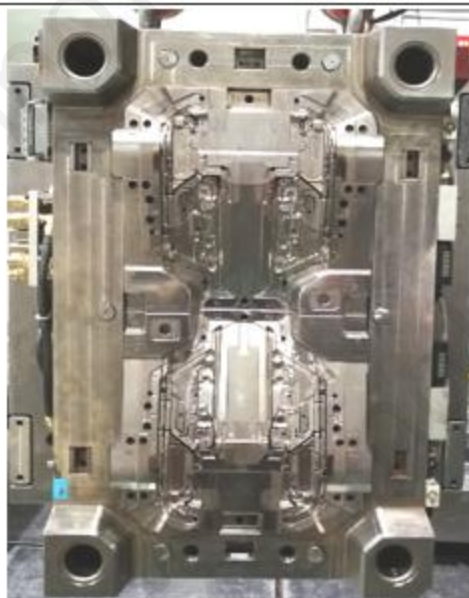

【Highlights: The cavity requires partial mirror polishing, with Primer free electroplating, and high mold temperature】

【Challenges: It is important to avoid issues such as iron powder contamination, scratches, and mirror distortion.】

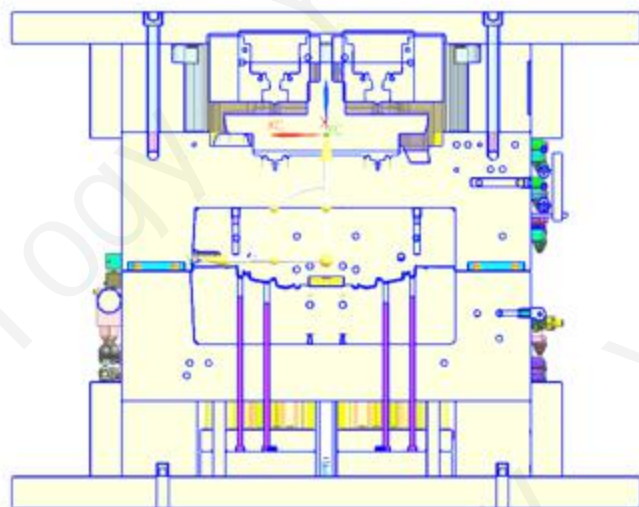

Product Information :

Customer : KOITO
 Product Name : 3*1D
 Product Name : TL HG REF
 Product Size : 191*98*96
 Product Material : PC black
 Product Weight : 111.3g

Tools Information :

Type: 850T, monochrome machine
 Hot Runner: masters 4 points needle valve
 Tool size: 1000*1000*786
 Tool Weight : 4023KG
 Cavity: 2+2
 Cycle time : 42S
 Make time : 2023.04



Primer free electroplating



【Highlights: The cavity requires partial mirror polishing, with Primer free electroplating, and high mold temperature】

【Challenges: It is important to avoid issues such as iron powder contamination, scratches, and mirror distortion.】

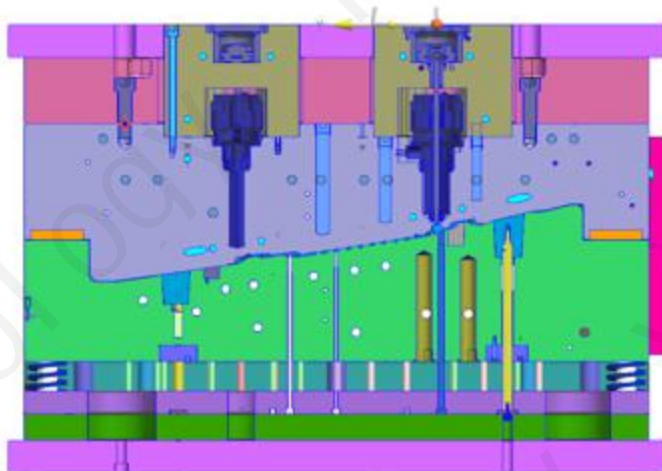

Product Information :

Customer : KOITO
 Product Name : H*3
 Product Name : A LAMP EXT-A
 Product Size : 668*135*110
 Product Material : PC black
 Product Weight : 151g

Tools Information :

Type: 850T, monochrome machine
 Hot Runner: masters 4 points
 needle valve
 Tool size: 1000*1000*680
 Tool Weight : 3665KG
 Cavity: 1+1
 Cycle time : 42S
 Make time : 2022.12



Primer free electroplating

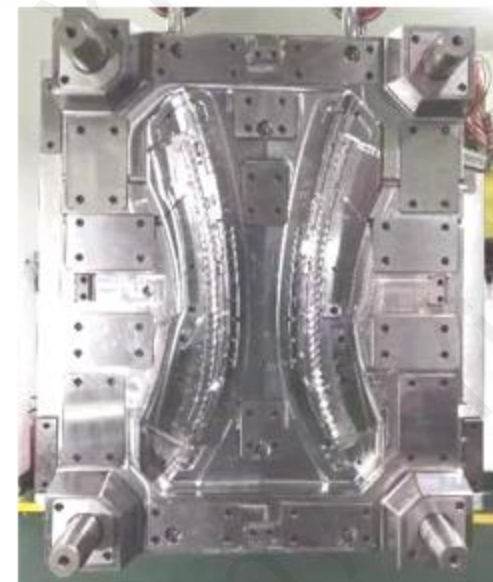

【Highlights: The cavity requires partial mirror polishing, with Primer free electroplating , and high mold temperature 】

【Challenges: It is important to avoid issues such as iron powder contamination, scratches, and mirror distortion.】

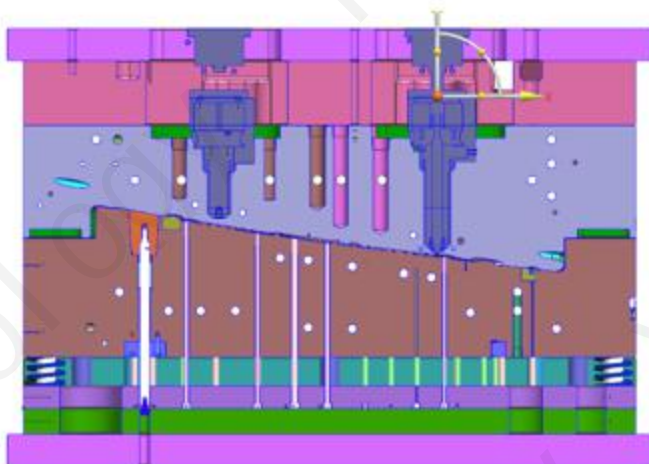

Product Information :

Customer : KOITO
 Product Name : H*3
 Product Name : A LAMP EXT-B
 Product Size : 668*135*110
 Product Material : PC black
 Product Weight : 140.1g

Tools Information :

Type: 850T, monochrome machine
 Hot Runner: masters 4 points
 needle valve
 Tool size: 1000*1000*680
 Tool Weight : 3665KG
 Cavity: 1+1
 Cycle time : 42S
 Make time : 2022.12

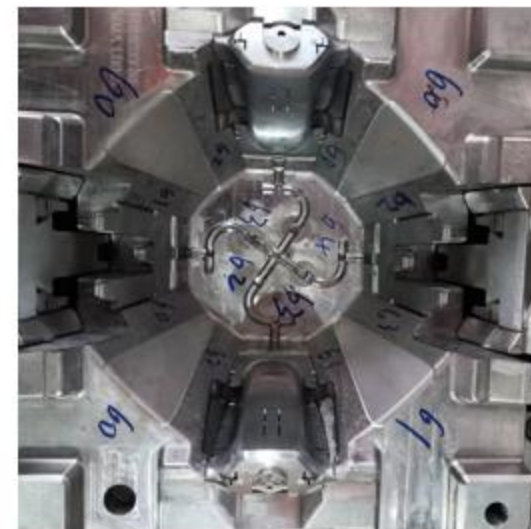

【Highlights: The cavity requires a mirror surface, eliminates the need for post-processing, and operates at a high mold temperature】

【Challenges: It is important to avoid issues such as iron powder contamination, scratches, and mirror surface deformation.】

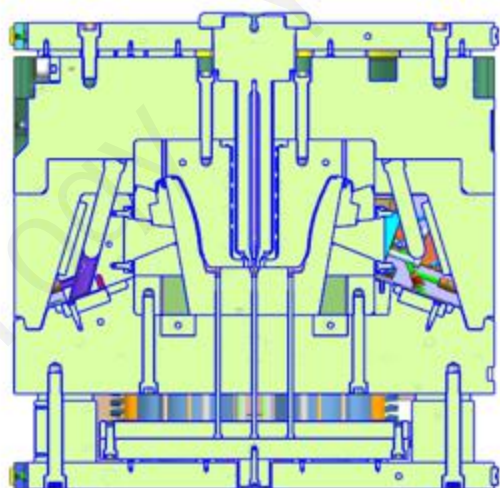

Product Information :

Customer : VALEO

Product Name : B*1E

Product Name : Camer Cover

Product Size : 79*66*118

Product Material : PMM High black bright

Product Weight : 40.1g+33.6g

Tools Information :

Type: 600T, 1K

Hot Runner: masters 1 points needle valve

Tool size: 1050*710*681

Tool Weight : 3010KG

Cavity: 2*2

Cycle time : 42S

Make time : 2022.05



Electroplate (Reflective face)

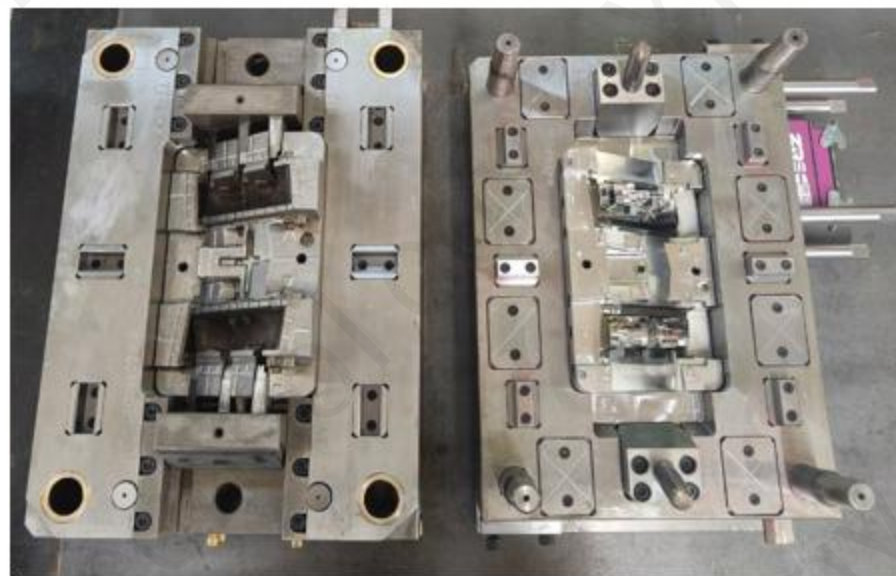

【Highlights: The cavity requires mirror polishing, with Primer free electroplating , and high mold temperature 】

【Challenges: It is important to avoid issues such as iron powder contamination, scratches, and mirror distortion. 】

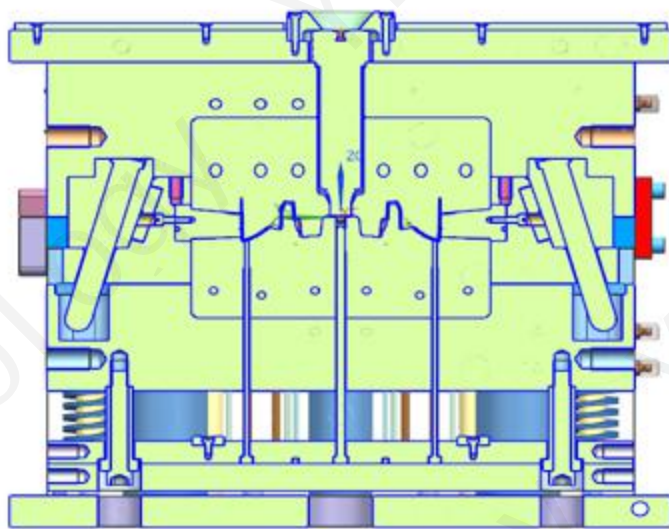

Product Information :

Customer : Tafu
 Product Name : A0505
 Product Name : Front fog lamp reflector
 Product Size : 136*87*137
 Product Material : PC High-gloss black
 Product Weight : g

Tools Information :

Type: 600T, monochrome machine
 Hot Runner: 1 points needle valve
 Tool size: 400*620*554
 Tool Weight : 870KG
 Cavity: 1+1
 Cycle time : 38S
 Make time : 2023.10



The above is the introduction,

Looking forward to cooperating with you,

Thanks!